

Scan here for
installation
videos

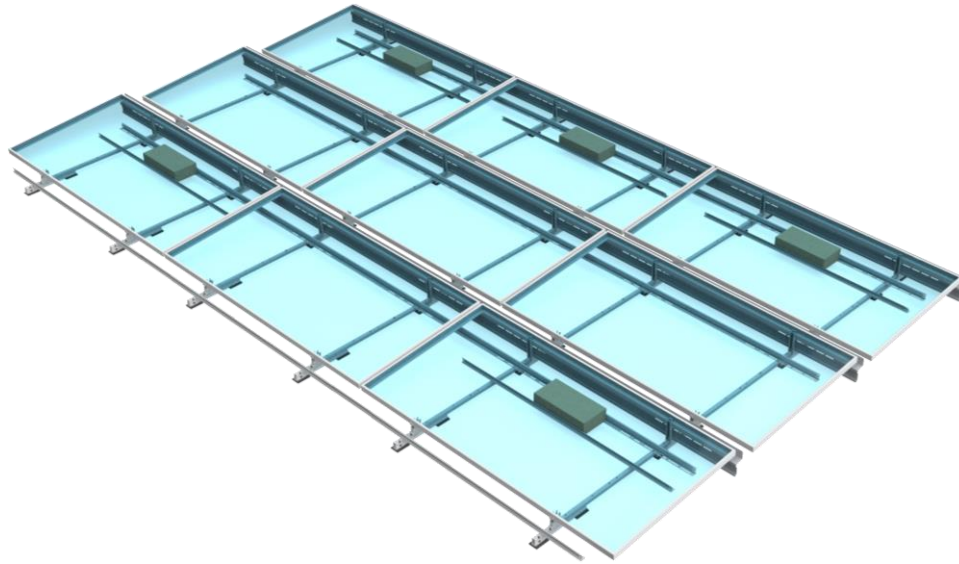

PANELCLAW®
AN ENSTALL COMPANY



clawFR 5 Degree Installation Manual

Table of Contents

Introduction & Safety Overview	2
Storage, Array Construction, and O&M considerations	3
System Components	4
Accessories	5
Tools, Torque, & Construction Aid	6
Construction Aid Setup	7
Build Assemblies	8
Build North Array Row	9
Build Remaining Rows	10
Place Ballast	12
Install Module Low Side	14
Install Module High Side	16
Continue Installing Modules	17
Install Deflectors	18
Cam & Lock Claw Inspection	19
Electrical Grounding	20
Appendix	21

ANSI/UL 2703/UL 3741

System Fire Class Rating: Class A for low slope roofs with Type 1, 2, 16, 19, 22, 25, 29, 30 and 38 Modules

Mechanical Load Rating: See [Appendix A: UL 2703 Grounding](#)

Introduction

The clawFR 5 Degree flat roof mounting system is comprised of four major components that intuitively assemble into a support structure for photovoltaic (PV) modules.

This installation manual explains how to build a PV array using clawFR 5 Degree.

 EXCEPT FOR DEFLECTORS, ALL RACKING COMPONENTS IN EACH SUBARRAY AND THEIR CONNECTIONS, BALLAST, AND MECHANICAL ATTACHMENTS (IF ANY IN DESIGN) MUST BE INSTALLED BEFORE MOUNTING MODULES. WHEN FORECASTED WIND GUSTS EXCEED 25% OF THE WIND SPEED LISTED IN THE SITE CRITERIA TABLE OF THE RACKING CONSTRUCTION SET, DEFLECTORS MUST BE INSTALLED ON ALL MOUNTED MODULES TO AVOID POSSIBLE SYSTEM DAMAGE.

 A CORROSION INSPECTION ONE YEAR AFTER INSTALLATION AND ONCE EVERY THREE YEARS THEREAFTER IS REQUIRED TO MAINTAIN THE PRODUCT WARRANTY. VISIBLE SURFACE RED RUST ON STEEL COMPONENTS MUST BE LOCALLY COATED WITH A COMMERCIALY AVAILABLE GALVANIZED PAINT OR COATING TO MAINTAIN PRODUCT WARRANTY.

 THIS PRODUCT MUST BE INSTALLED AND USED ACCORDING TO THIS WRITTEN INSTRUCTION. ANY INSTALLATION OR USE OF THIS PRODUCT NOT IN ACCORD WITH OR NOT AUTHORIZED BY THIS WRITTEN INSTRUCTION SHALL VOID ANY AND ALL WARRANTIES, EXPRESS OR IMPLIED, ON THE PRODUCT OR THE USE OF THE PRODUCT AND MAY CAUSE FAILURE, PROPERTY DAMAGE AND PERSONAL INJURY. PANELCLAW IS NOT LIABLE FOR ANY UNAUTHORIZED USE. INSTALL AND USE ONLY WITH OTHER PANELCLAW **AUTHORIZED** RACKING PRODUCTS TO ENSURE PROPER FIT AND FUNCTION.

Installer's Responsibility

IT IS THE INSTALLERS RESPONSIBILITY TO:

- Ensure safe installation of all electrical aspects of the array. All electrical installation and procedures should be conducted by a licensed and bonded electrician or solar contractor. Routine maintenance of a module or panel shall not involve breaking or disturbing the bonding path of the system. All work must comply with national, state and local installation procedures, product and safety standards.
- Comply with all applicable local or national building and fire codes, including any that may supersede this manual.
- Ensure all products are appropriate for the installation, environment, and array under the site's loading conditions.
- Use only PanelClaw parts or parts recommended by PanelClaw; substituting parts may void any applicable warranty.
- Ensure provided information is accurate. Issues resulting from inaccurate information are the installer's responsibility.
- Ensure bare copper grounding wire does not contact aluminum and zinc-plated steel components, to prevent risk of galvanic corrosion.
- If loose components or loose fasteners are found during periodic inspection, retighten immediately. Any components showing signs of corrosion or damage that compromise safety shall be replaced immediately.
- Provide an appropriate method of direct-to-earth grounding according to the latest edition of the National Electrical Code, including NEC 250: Grounding and Bonding, and NEC 690: Solar Photovoltaic Systems.
- Disconnect AC power before servicing or removing modules, AC modules, microinverters, and power optimizers.
- Review module and any 3rd party manufacturer's documentation for compatibility and compliance with warranty terms and conditions.

Safety Overview

Safety is an essential part of every PV installation and every construction site. It is imperative to plan ahead for any safety concerns and hazards to promote safe work practices during installation. This section does not claim to address or support all safety concerns that may arise during the installation of PanelClaw mounting systems or any other aspect of the work being performed. Before beginning work, installers should refer to all local and federal safety, health, and regulatory requirements to assure compliance. Refer to OSHA Part 1926 and its related Subparts for federal construction related regulations and standards.

Appendix J: Safety outlines some of the major hazards to be aware of during the installation of PanelClaw products.



PRIOR TO INSTALLATION, READ THE SAFETY PROVISIONS ATTACHED IN [Appendix L: Safety](#) AND REVIEW THIS INSTALLATION MANUAL IN ITS ENTIRETY.

Operations & Maintenance

See O&M Manual, available upon request, for initial inspection recommendations including steps that can be performed only during construction.

Sub Array Dimensions

Each PV system is unique and is frequently made up of multiple sub arrays. The Racking Construction Set, which must be onsite at all times during construction, details sub array dimensions and location on the roof. Review the Racking Construction Set in its entirety to prevent unnecessary rework during site construction.

The furthest extent of the racking components or modules of adjacent sub arrays, whichever defines the outermost array boundaries, must be separated by *at least* the minimum dimensions documented in the Racking Construction Set. Refer to the **general notes** and the **Minimum Clearance Requirements table**, if present, within the Racking Construction Set.

Storage Considerations

PanelClaw recommends installing the racking components shortly after delivery to the project site. If clawFR components are not deployed immediately, they should be stored in a well-ventilated, dry location. Otherwise, moisture can form between the packed components which may cause staining and/or white rust. Significant white rust formation may decrease the coating service life and, in extreme cases, the component performance.

If storage onsite is unavoidable, remove the plastic and/or cardboard wrapping from the exterior of the packaging and cover with canvas or place components under an open sided tent. Note the use of a plastic cover does more harm than good as it prevents the product from breathing and causes condensation. Storing parts in any other manner is at the customer's **own** risk. PanelClaw is not liable for claims related to improper storage and any such claims are not covered by the product warranty.

System Components



Base
500050202



Module Connector
5000523XX

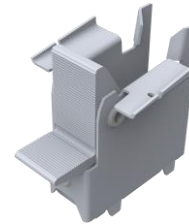

Cam
5000515

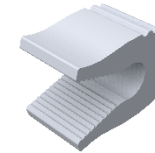

Cam Claw
2000673



M6x16mm Bolt
2000697



Rail
2000695/2000895



Wind Deflector
2000899XX

Module Adapters

See: Appendices D-J



Lock Claw Clip
2000819/5000419

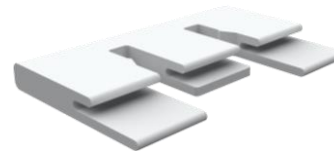

Frame Enhancer
2000832/5000532

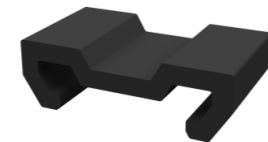

Cam Seat Spacer
2000833/5000533



Ballast Block: Solid cap concrete roof paver, conforms to ASTM C1491 or C1884 standard and manufactured for freeze-thaw resistance where applicable. See Appendix C for more details

Accessories

See: Appendices D-J



MLPE Attachment
5000519

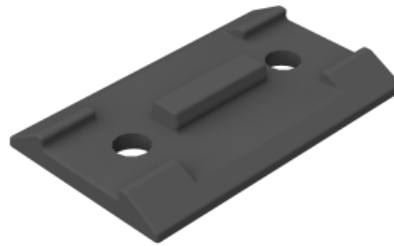

Base Pad
2000678

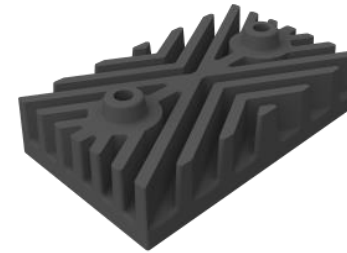

Shim Pad
5000228

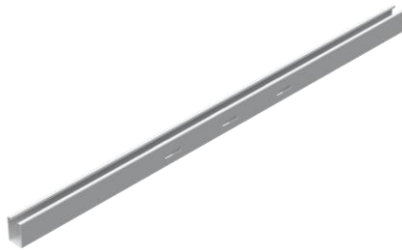

Mechanical Hardware Kit
5000423



Ground Lug Kit
5000494

Note: Use of non-UL listed accessories, including non-metallic components, **does not** affect the system ANSI/UL 2703 certification.

Wire Management Accessories

See: 9910053-Wire Management Manual



Wire Clip
5000226



WM Homerun
500062302
and 5000628

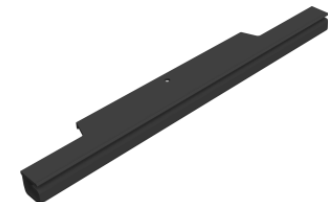

Wire Router
5000225XX

Construction Aids



Spacer Stick

Cam Spacer / Lock Claw Insertion Depth Gauge

Spacer Stick and Cam Spacer Kit
5000510/5000610
2000761 may be required

Tools

Drill with Inline-Torque Limiter or Torque Wrench

10 mm Magnetic Nut Driver

ALERT: NO IMPACT DRIVERS

Torque Setting*	Fastening Operation
6 ft-lb (8.1 Nm)	All System connections except Special Cases
3 ft-lb (4.1 Nm)	Special Cases, See pg. 11

* +/-4% allowable during installation

Note: Additional tools may be required when installing accessories.

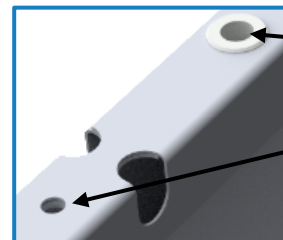

Bolts which are installed into a pre-installed nut are tightened to **6 ft-lb**

Bolts which are installed into a pilot hole are tightened to **3 ft-lb**, See [pg. 11](#)

1. Construction Aid Setup

Tip: L, S, and Cam Spacer dimensions are found in the Racking Construction Set. See Sheet Title: Typical Array Dimensions.

1.1 Assemble the Spacer Stick and adjust to L & S dimensions. All dimensions are measured from the Base centerlines.

Tip: To stiffen the Spacer Stick, place one Rail 2000695/2000895 on the assembly as shown, shift the Rail to find a location which allows for attachment with the specified bolts. Tighten the bolts.

1.2 Insert the bolt and adjust the Cam Spacer to the Cam Spacing dimension.

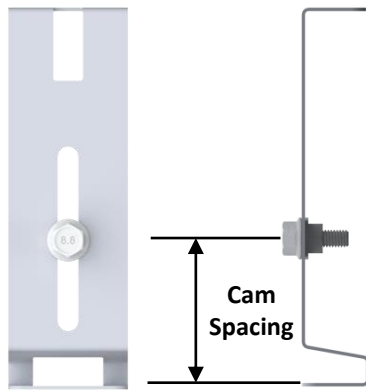
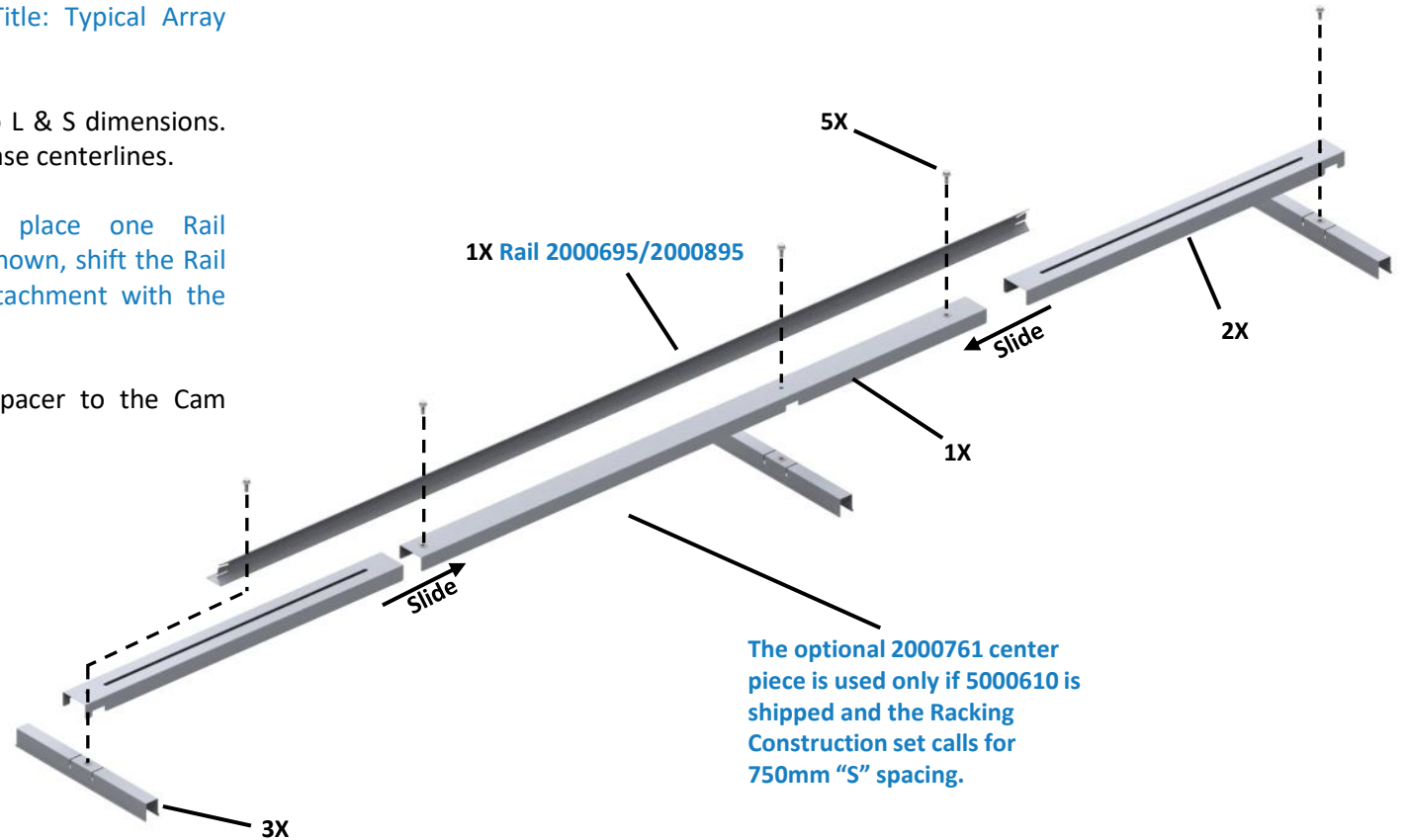

Cam Spacer / Lock Claw Insertion Depth Gauge

Typical Cam Spacer Usage

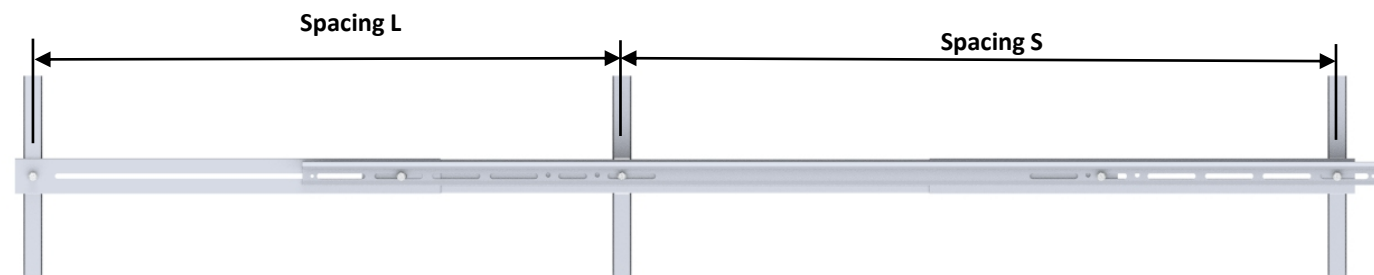
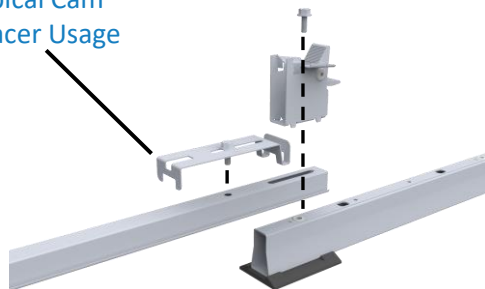

Adjust Spacer Stick

2. Build Assemblies

Scan here for
Assembly Jig
Manual



2.1 Position components as required per assembly type and loosely assemble the Cam, Module Connector and Base.

ALERT: Note location of orientation marker on Base “●”

Tip: Base length may vary depending on the row spacing option.

Tip: Immediately tighten bolts to **6 ft-lb** which are at the Tilt Arm end of the assembly.

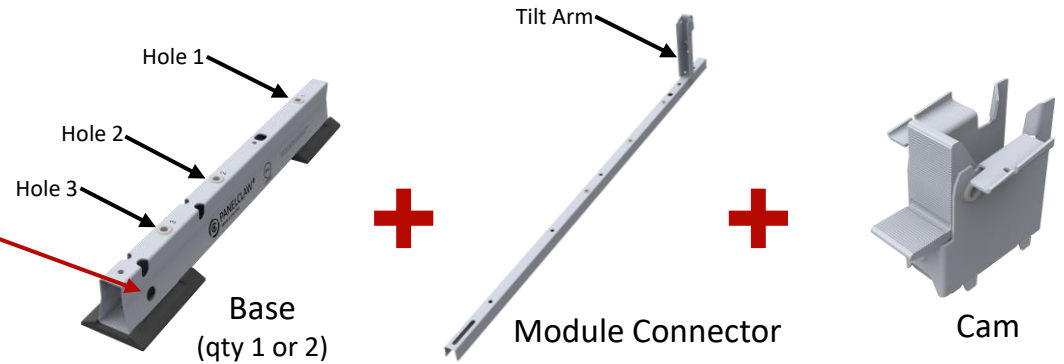

2.2 Use the Cam Spacer tool to correctly locate the module connector. Tighten bolt to **6 ft-lb**.

Tip: If Cam Seat Spacer module adapters are required, install them now.

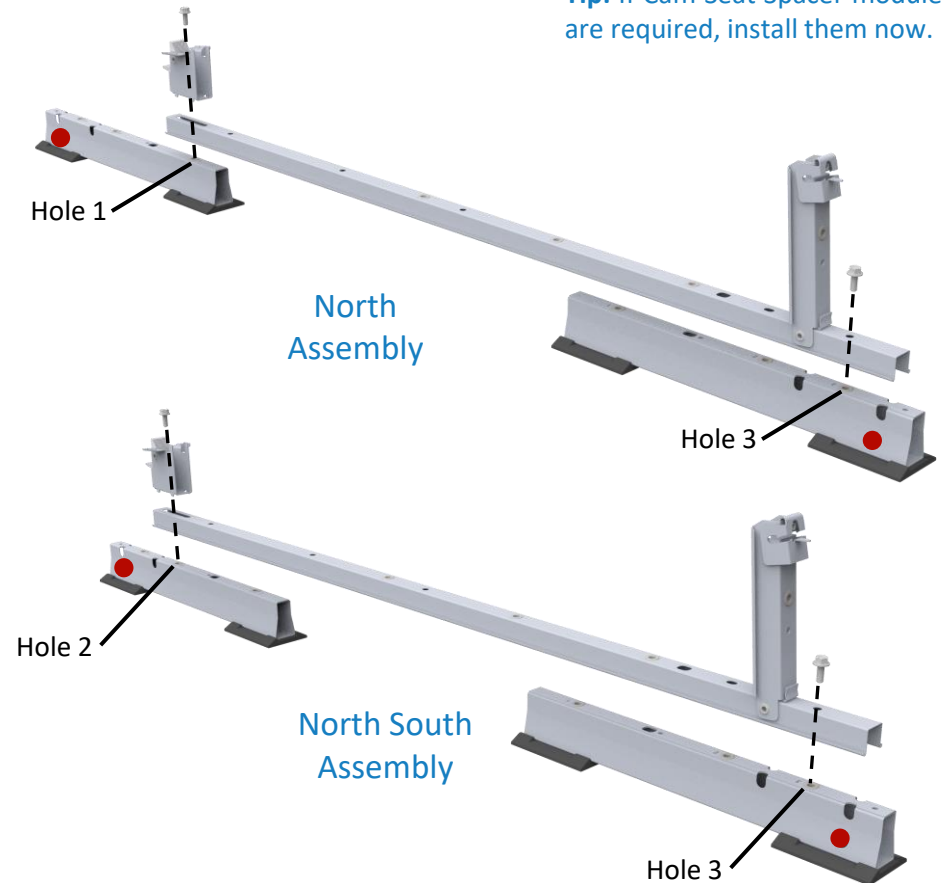
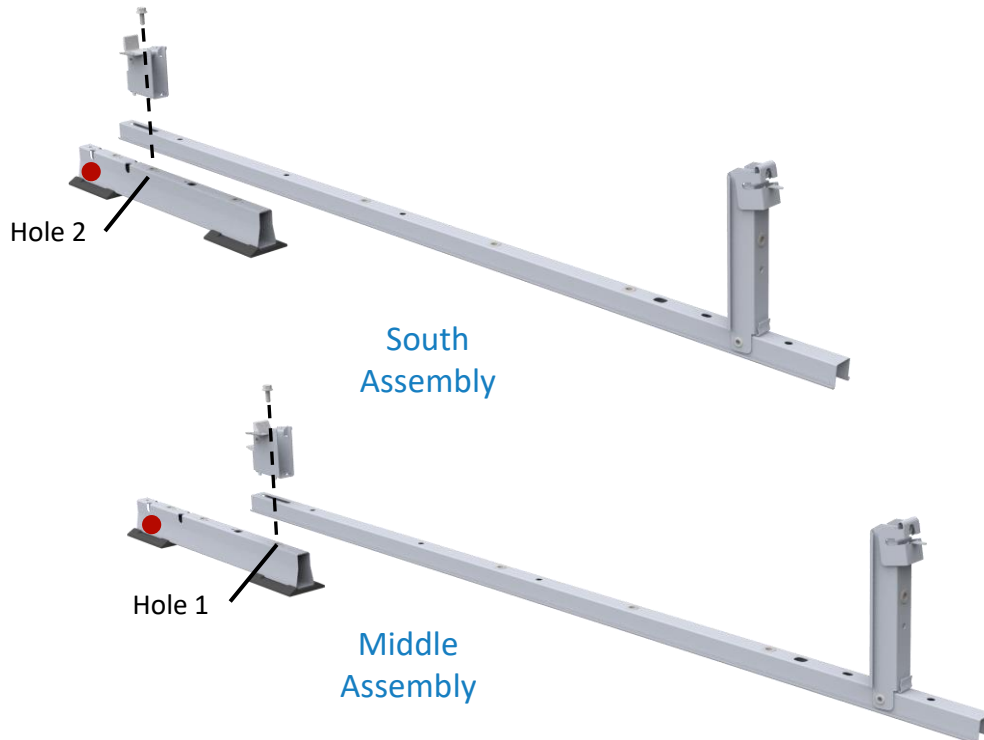

3. Build North Row

Scan here for rail installation video



3.1

See Sheet Title: Typical Array Dimensions in the Racking Construction Set for AEBE dimension.

Snap North Edge, Array Edge, and Base Edge lines.
Tip: Snap Array Edge lines on one or both array edges (row ends) and snap Base Edge line on the edge where module mounting will begin.

ALERT: To ensure system alignment, use the Spacer Stick to align Module Connectors before securing Rails.

Tip: L, S, R and AEBE dimensions are found in the Racking Construction Set. See Sheet Title: Typical Array Dimensions.

Tip: "S" spacings are module centered "L" spacings are between modules.

3.2

Tip: Base Edge is in line with Base Pad

Base edge measured to Pad edge

Place North Assemblies with the Base Pads along the North Edge line. The first and last North Assemblies should be placed with the edge of the Base Pads on the Base Edge line.

Tip: Raise Tilt Arms after securement of assembly.

3.3

Place a Rail on all "S" spacings (module centered). Rails at ends of rows should be flush with array edge when "S" spacings permits.

Place a Rail on all "L" spacings (between modules) on top of and overlapping the Rails on the S spacing. Install bolt and tighten to **6 ft-lb.**

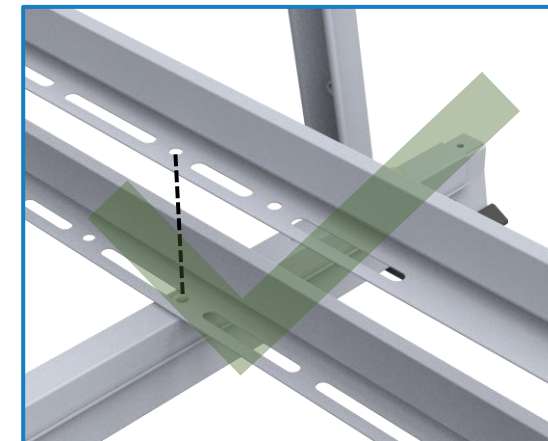

ALERT: Rail on "L" Spacing is ALWAYS on top of Rail on "S" Spacing. This installation sequence is **critical** to system performance.

Tip: Rail has two holes. Consult Sheet Title: Typical Array Dimensions in the Racking Construction Set for appropriate hole use.

4. Build Remaining Rows

Tip: Raise Tilt Arms after bolting assemblies in preparation for Rail installation.

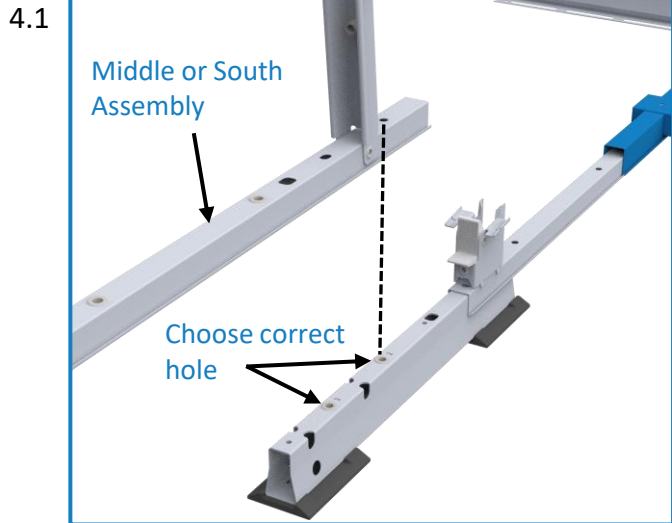
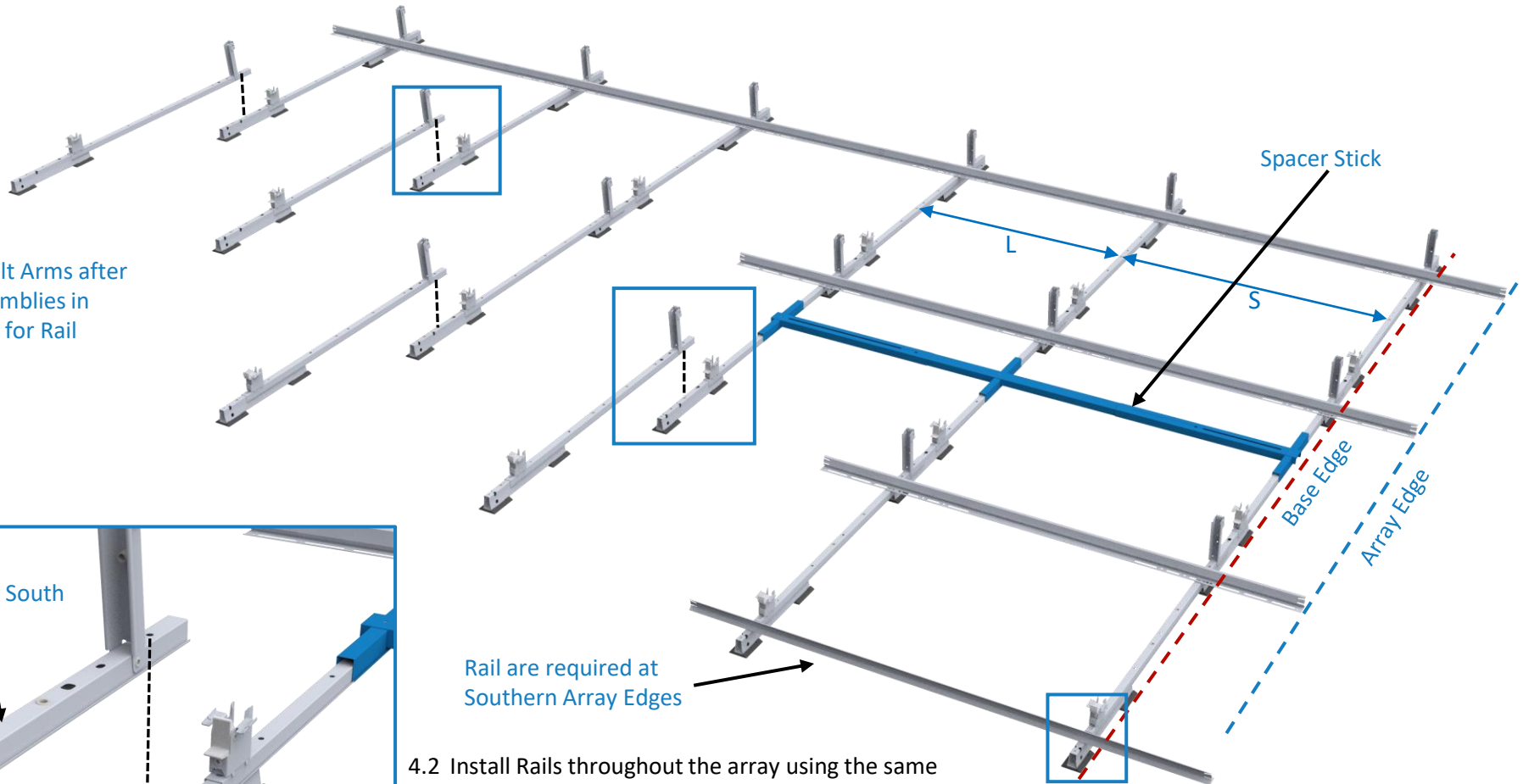

Place Middle or South assemblies onto Assemblies from previous row and bolt to **6 ft-lb**.

Tip: Sheet Title: Assemblies in the Racking Construction Set clearly indicates hole selection. Using the wrong hole will result in an array which does not match site plan.

Rails are required at Southern Array Edges

4.2 Install Rails throughout the array using the same steps described on the previous page. Alternating between "S" and "L" Spacings. Install bolt and tighten to **6 ft-lb**.

ALERT: To ensure system alignment, use the spacer stick to align Module Connectors before securing Rails.

ALERT: Tighten fasteners prior to moving spacer stick to next position.

ALERT: Installation of Southern Array Edge Rails is **critical** to system performance.

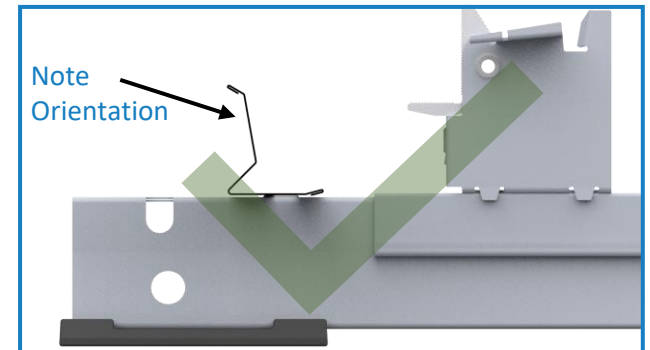

ALERT: Southern Edge Rails face the opposite direction; bolts securing these rails are tightened to **6 ft-lb**.

4. Build Remaining Rows (Continued)

Rail Configurations for South Interior Corners

In cases where a contiguous array has module omissions additional Rails must be installed as shown.

Alert: Modules are included for illustrative purposes only

Scan here for common rail installation mistakes



PANELCLAW®
AN ENSTALL COMPANY

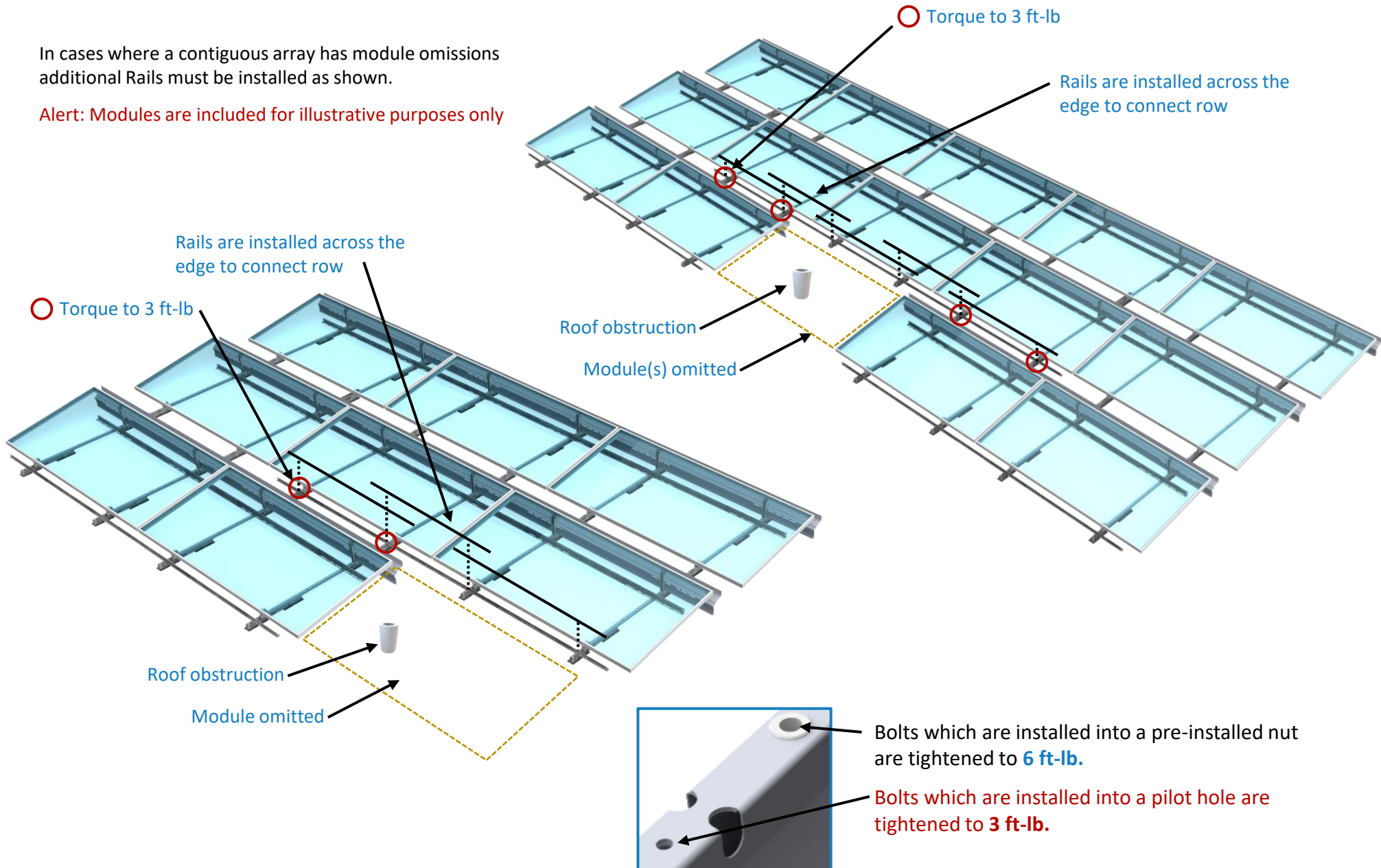

5. Place Ballast

Tip: Sheet Title: Ballast Layout –XX in the Racking Construction Set identifies where Ballast is to be installed. Mark the roof with chalk to speed up installation.

5.1 Install Rails in locations where Ballast is required. Bolt Rails to Module Connectors using preinstalled nut closest to the Tilt Arm and tighten to **6 ft-lb**.

ALERT: Every Rail must be fastened to two Module Connector assemblies.

Tip: Ballast and Rails are only placed on “S” spacings. Center them on the “S” spacing as shown for equal ballast distribution.

5.2 Place Ballast onto Rails. If rapid cyclic movement of system is expected e.g. due to seismic activity or building vibration from activities within or nearby the structure, bend the Rail tabs to secure Ballast.

ALERT: Install Mechanical Attachments before going to next step. See Appendix D.

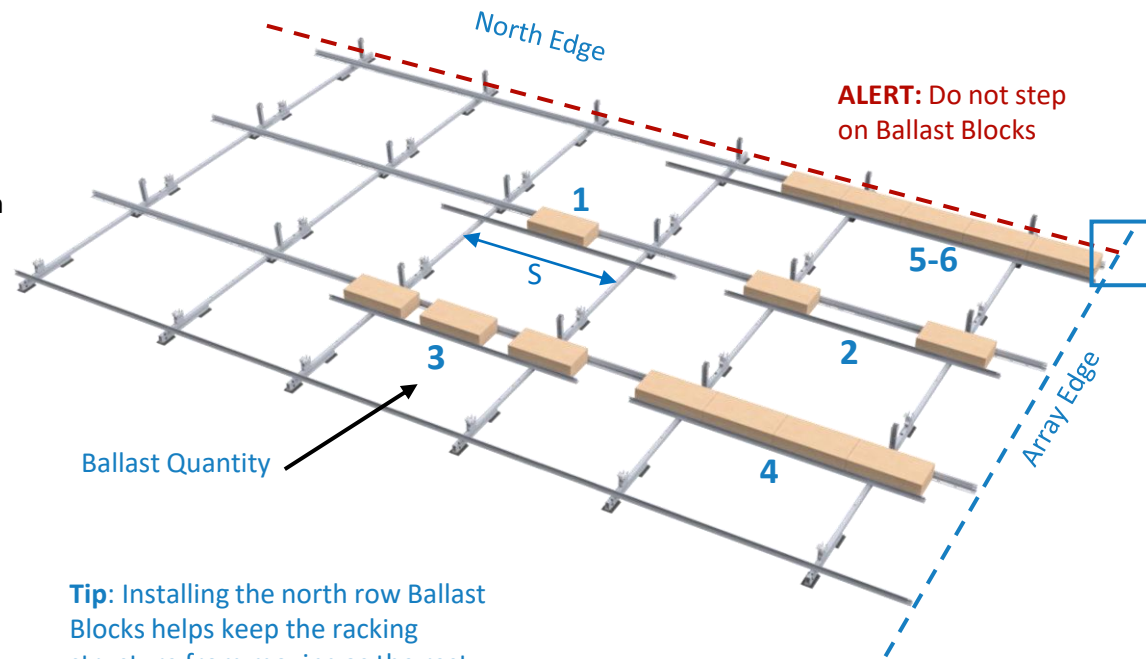

Tip: Installing the north row Ballast Blocks helps keep the racking structure from moving as the rest of the array is built.

When **1-4 Ballast Blocks** are required only a **single** Rail centered under the module is required.

See next page for 5-6 **Ballast Block** installation.

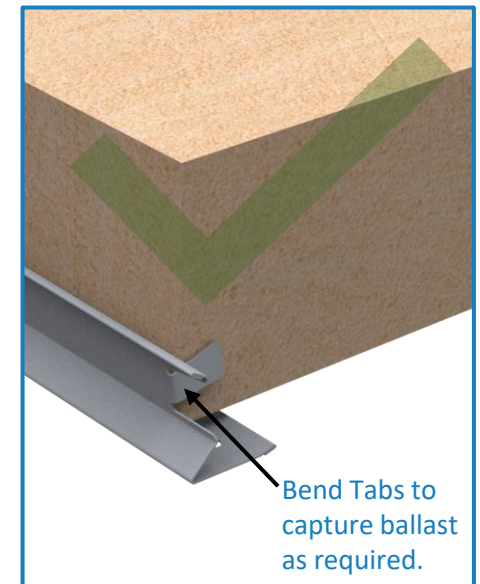
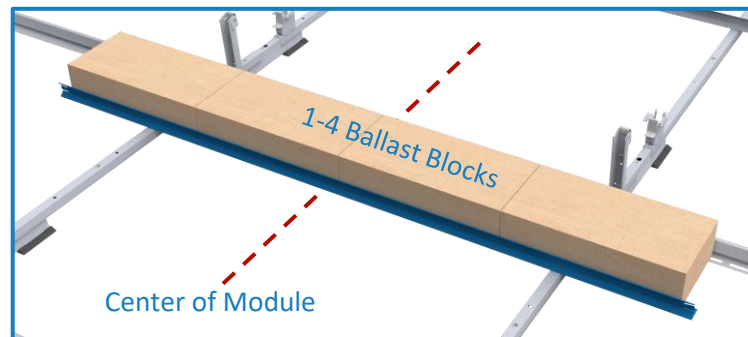

Bend tabs at ends of Rail.
 (See 5.2 to determine if required)

5. Place Ballast (Continued)

5.3 When 5-6 Ballast Blocks are required two Rails are needed. The first Rail is placed on the two Module Connectors supporting the ballast for the module and then shifted east or west to align with one edge of the module (dimension R). The second Rail is placed on top of the first Rail and centered on spacing "L". Bolt Rail to Module Connectors and tighten to 6 ft-lb.

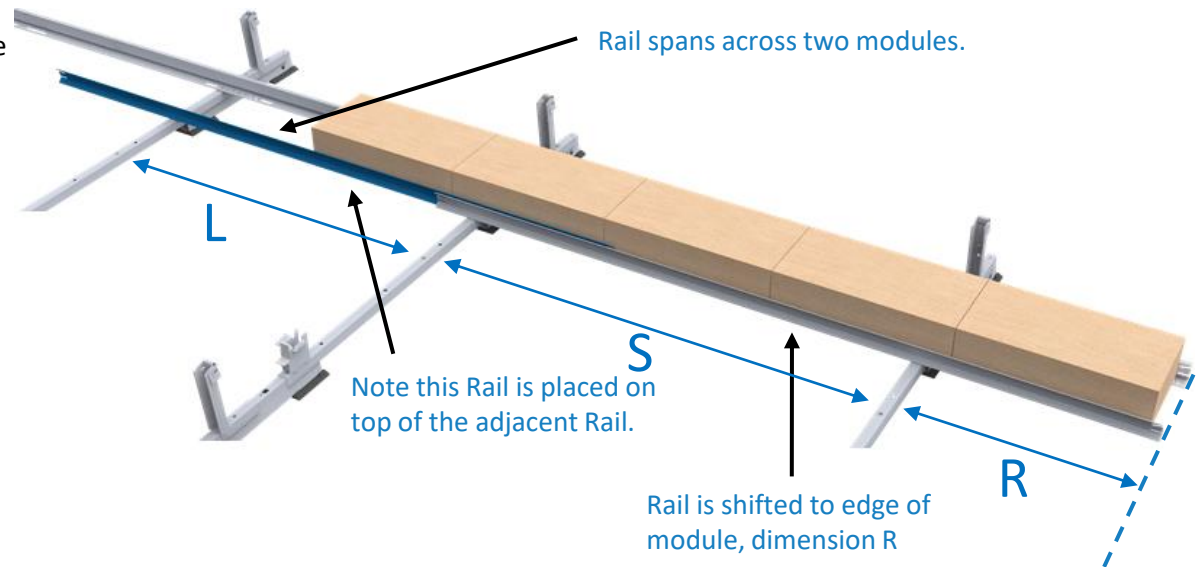

ALERT: Every Rail must be fastened to two Module Connector assemblies.

ALERT: Only modules longer than 2400mm may use up to 6 Ballast Blocks.

ALERT: Install Mechanical Attachments before going to next step. See Appendix D.

Tip: Place Ballast Blocks centered on the module. If the module length is too short to fit 5-6 blocks underneath, shift ballast towards the array interior so the Rails and ballast do not extend past the edge of the array perimeter.

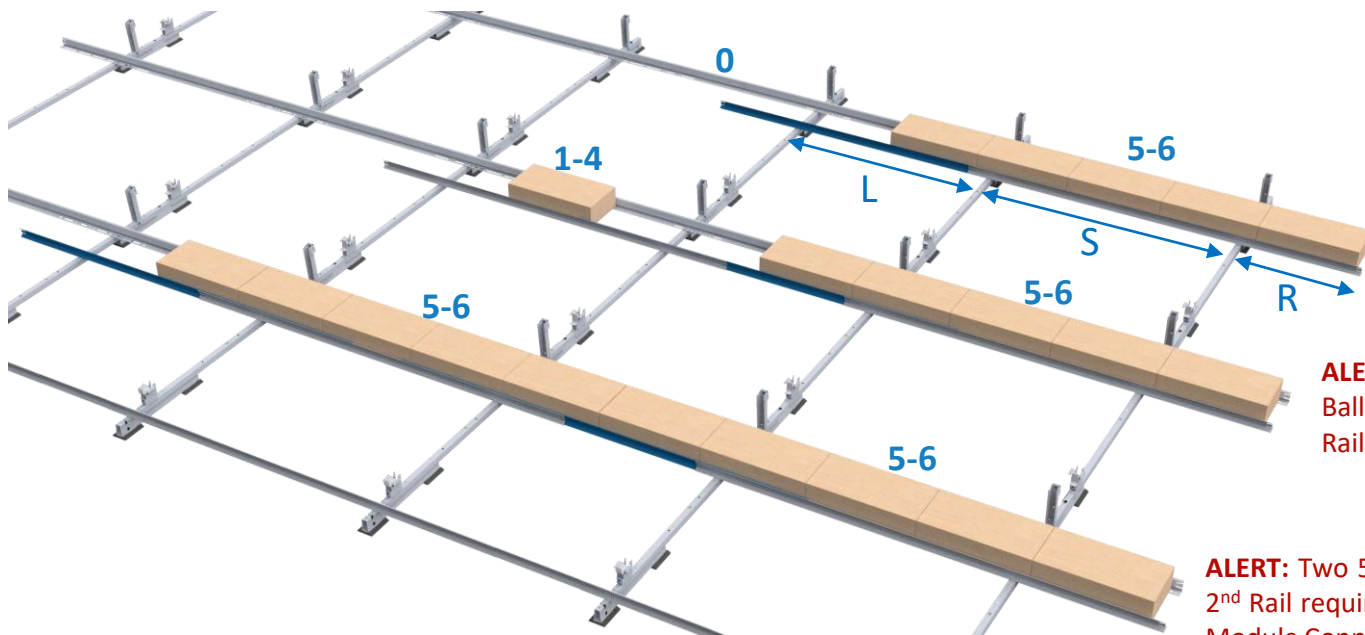

ALERT: 5-6 Ballast Block module next to 0 Ballast Block module: 2nd Rail spans across to adjacent Module Connector.

ALERT: 5-6 Ballast Block module next to 1-4 Ballast Block module: 2nd Rail overlaps adjacent Rail.

ALERT: Two 5-6 Ballast Block modules next to each other: 2nd Rail required for each module spans across to adjacent Module Connector.

6. Install Module Low Side

Scan here for
module
installation
video



ALERT: Install Mechanical Attachments before installing modules. See Appendix D. Install Cam Seat Spacer, if required, before installing modules. See Appendix J for instruction.

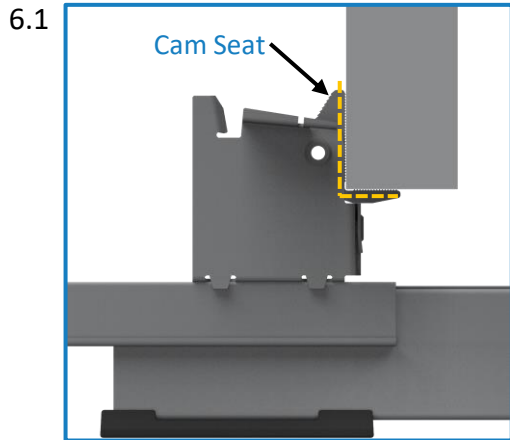

Place module on Cam Seat and align with Array Edge.

Tip: Ensure the module is vertical and flush with Seat.

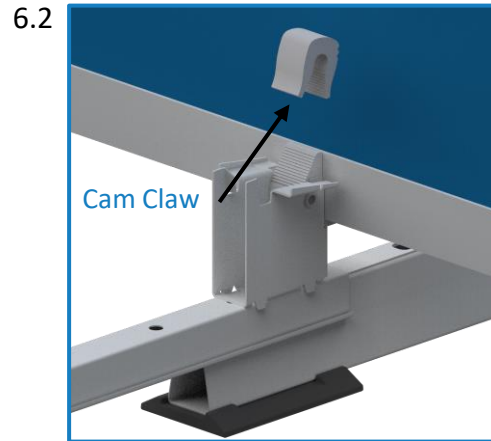

Place Cam Claw over module flange.

Apply a small downward force to make sure it is properly seated.

Tip: Cam Claw grooves may be ignored for installation purposes

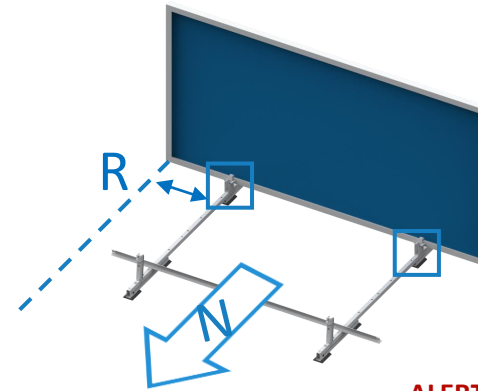

Tip: R dimension is found in the Racking Construction Set. See Sheet Title: Typical Array Dimensions

Tip: Installing modules starting at the south array edge provides more working room and speeds installation.

ALERT: Do not leave modules in vertical position, go immediately to next installation step (high side install).

ALERT: When forecasted wind gusts exceed 25% of the wind speed listed in the site criteria table of the Racking Construction Set, Deflectors must be installed on all mounted modules to avoid possible system damage.

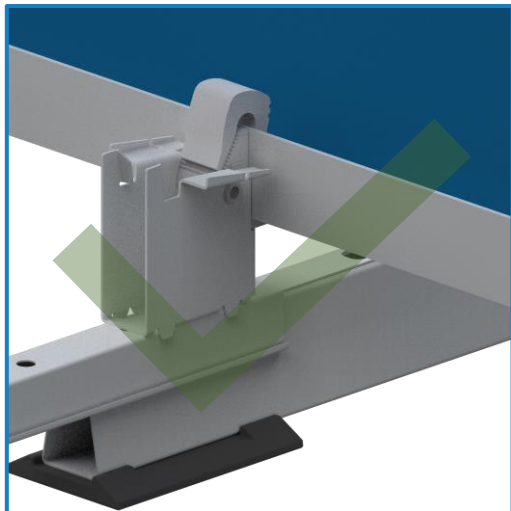

Cam Claw aligned

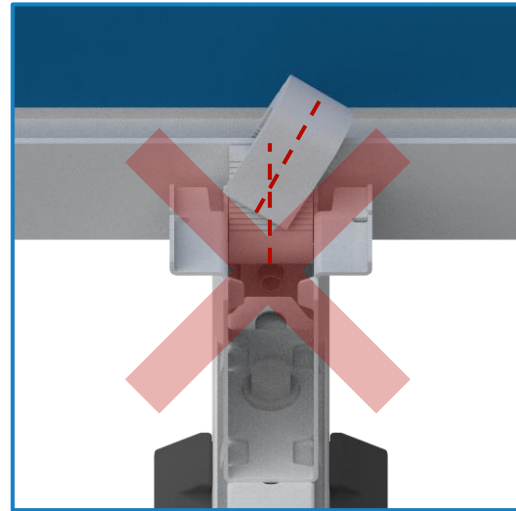

ALERT: Cam Claw is mis-aligned.

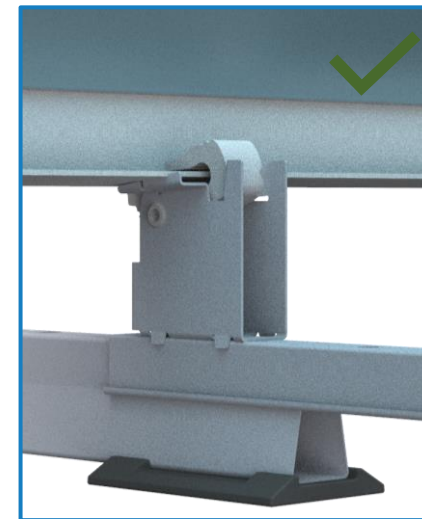

Example of a typical good Cam Claw install, after the module has been rotated down and high-side has been installed

6. Install Module Low Side (Continued)

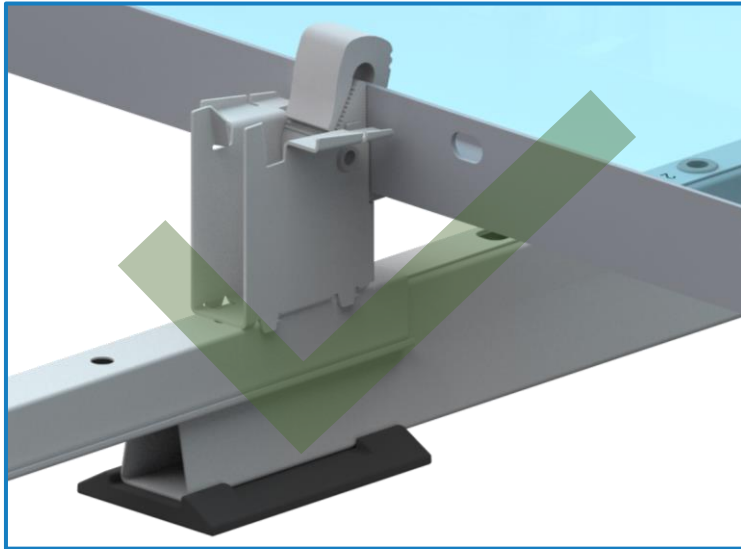

Cam flanges are located away from the module mounting holes

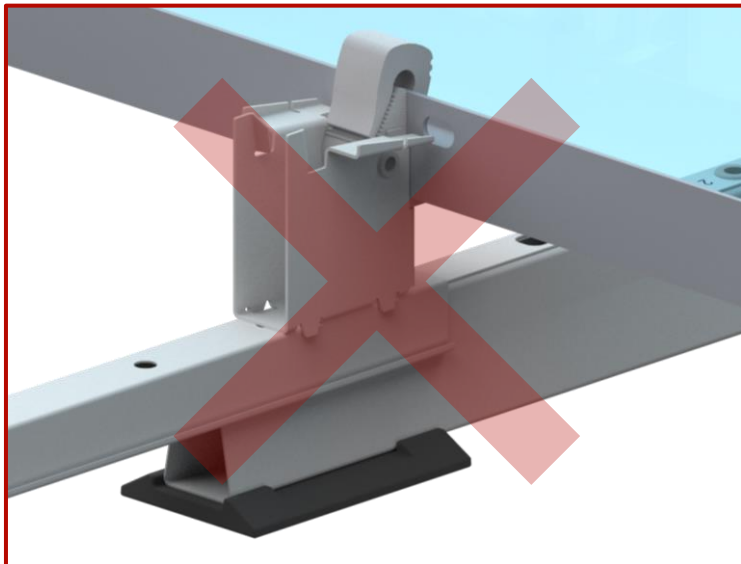

If Cam flanges align with the module mounting holes, Contact PanelClaw. Consult Sheet Title: Typical Array Dimensions in the Racking Construction Set to verify that appropriate R dimension is in use.

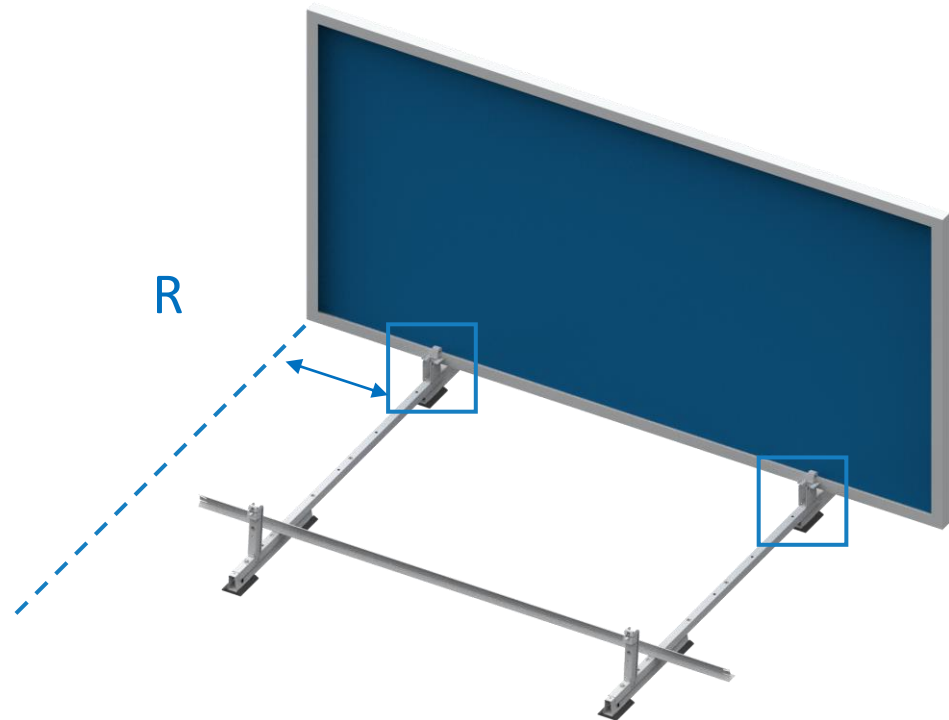

7. Install Module High Side

Scan here for
module high
side installation
video

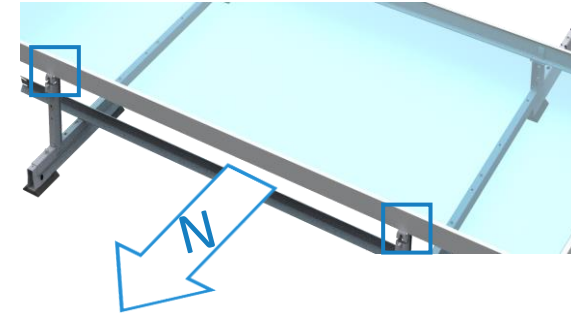
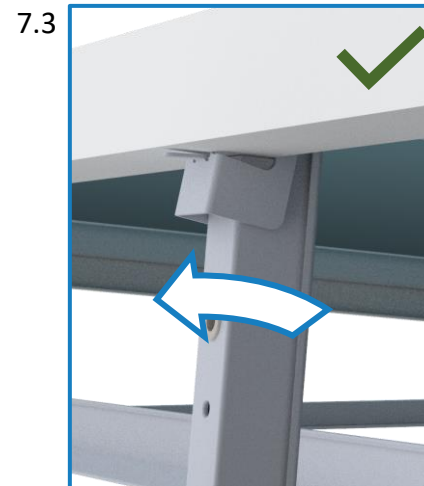
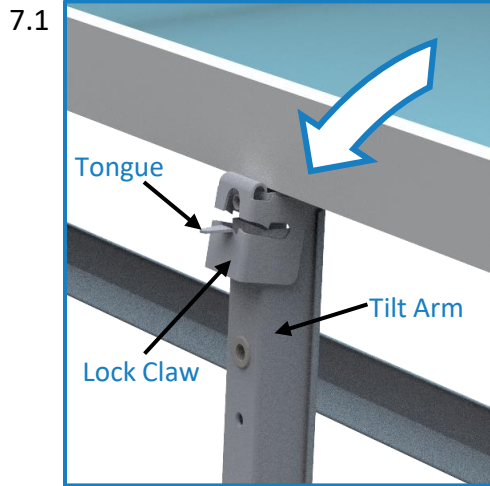

Rotate module down and rest the module frame on the top of the Tilt Arms.
Tip: Make sure the Tilt Arms are fully raised.

Support module while carefully rotating the Tilt Arm just enough to rest the module frame on the Lock Claw tongue.

Pull the Tilt Arm forward until the Lock Claw is fully engaged onto the module frame flange.

Tip: Use two hands when engaging Lock Claw to ensure correct installation.

Tip: See [Appendix I](#) for Lock Claw reset method.



DO NOT REST MODULE BACKSHEET ON TILT ARM

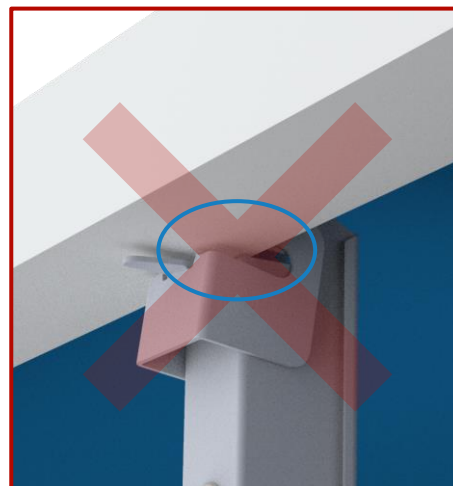

LOCK CLAW NOT FULLY ENGAGED

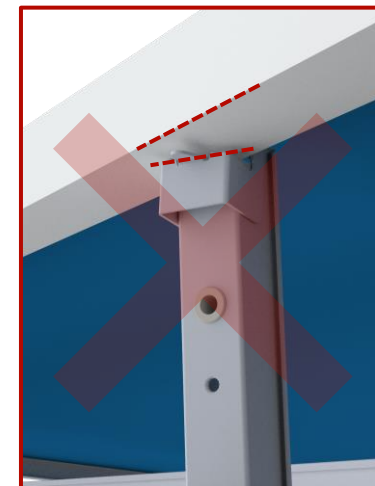

LOCK CLAW UNEVENLY ENGAGED

7. Continue Installing Modules

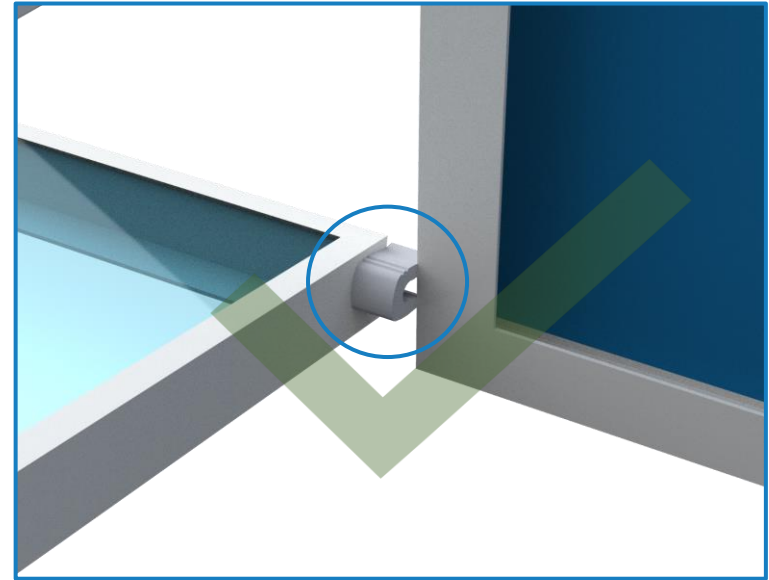
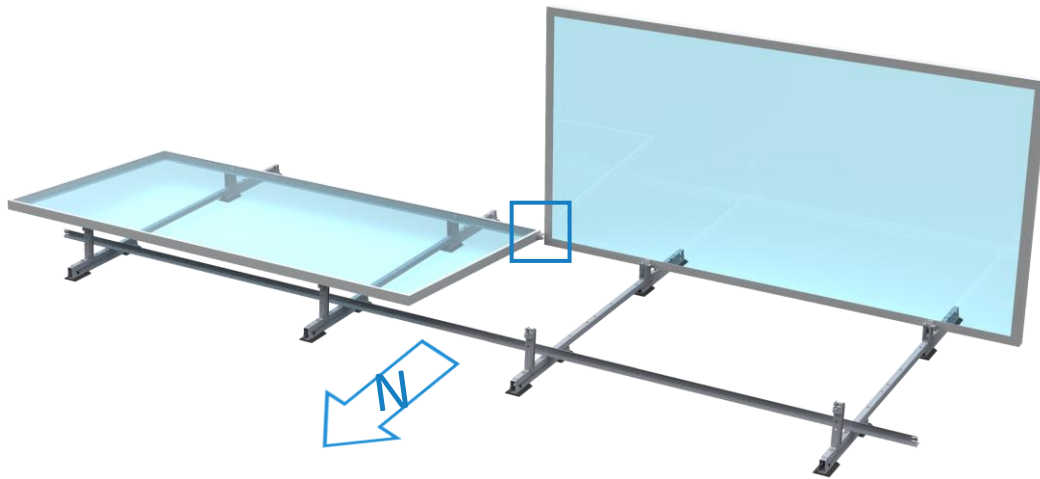

Use Cam Claw as spacer to set spacing between modules.

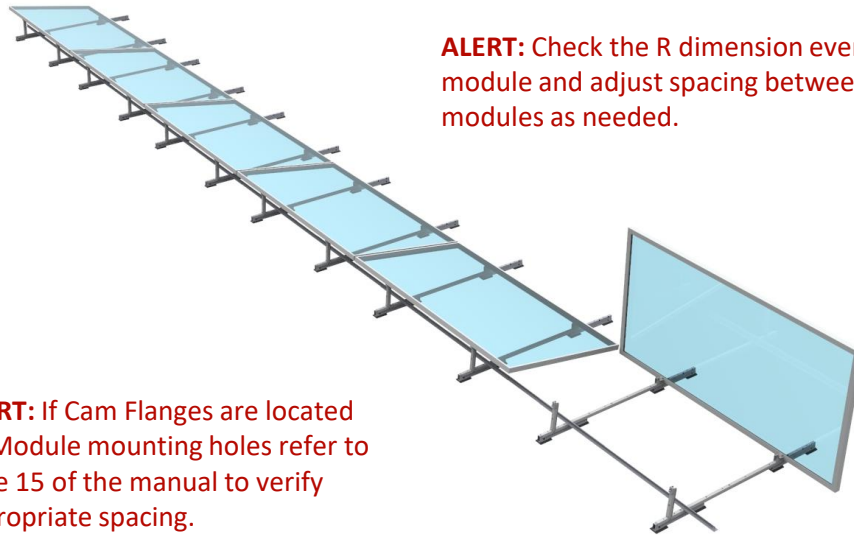

ALERT: Check the R dimension every 5th module and adjust spacing between modules as needed.

ALERT: If Cam Flanges are located on Module mounting holes refer to page 15 of the manual to verify appropriate spacing.

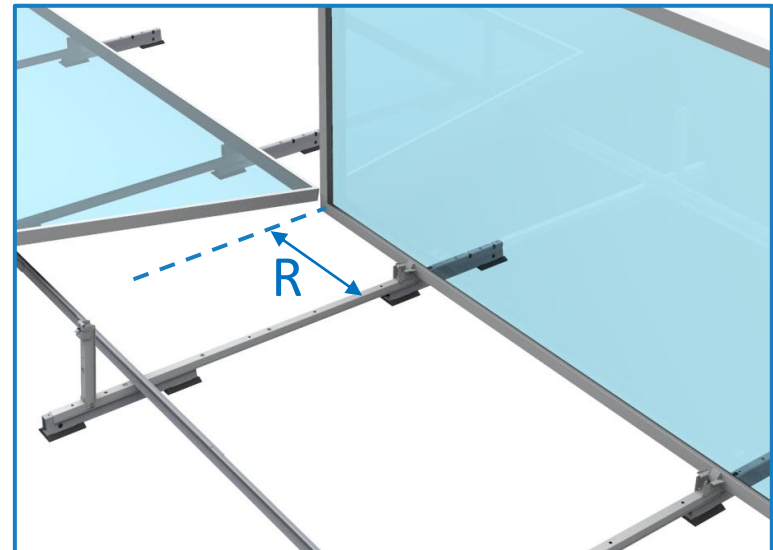

Tip: R dimension is found in the Racking Construction Set. See Sheet Title: Typical Array Dimensions.

8. Install Deflectors*

ALERT: When forecasted wind gusts exceed 25% of the wind speed listed in the site criteria table of the Racking Construction Set, Deflectors must be installed on all mounted modules to avoid possible system damage.

If Lock Claw Clip and/or Frame Enhancer module adapters are required they should be installed prior to installing Deflectors. See Appendix for instructions.

8.1

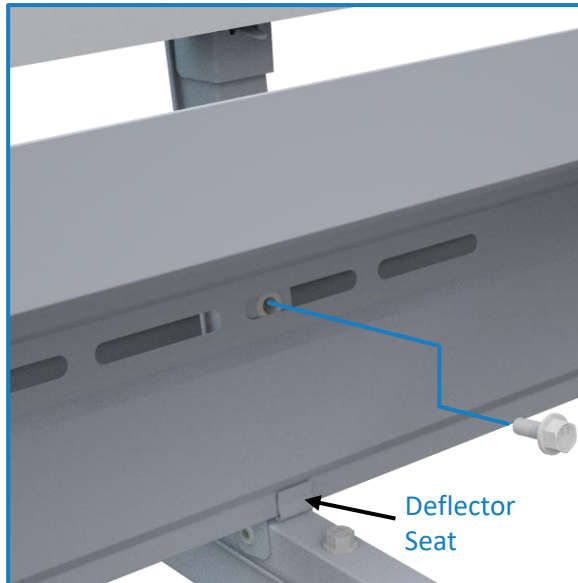

Place the bottom edge of the Deflector in the Deflector Seat near the bottom of the Tilt Arm.

Fasten to Tilt Arm with bolt and tighten to **6 ft-lb.**

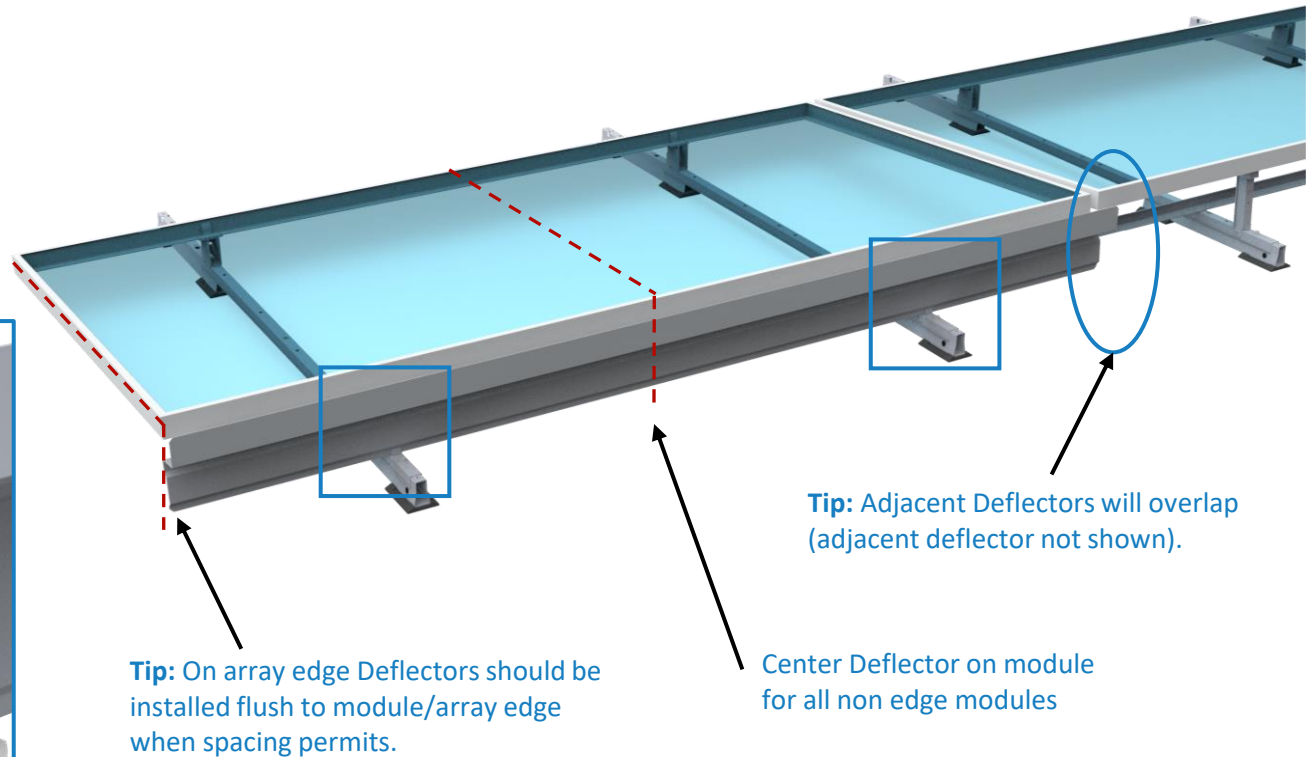

* Consult Sheet Title: Ballast Layout –XX in the Racking Construction Set for deflector requirement. Each Array will specify required Deflectors per array.

9. Cam & Lock Claw Inspection

Cam installation can be quickly visually inspected (no gauge is available or required) by comparing a known good installation with all other installations.

Some gap between Module and Cam is permissible. The graphics are representative only; actual installation geometry varies by module vendor and part number. **If it is not clear the module low side connection is good, contact PanelClaw for assistance.**

ALERT: Verify correct installation by lifting up on the module near the Cam and making sure no movement occurs.

Inspect Cam side module connection

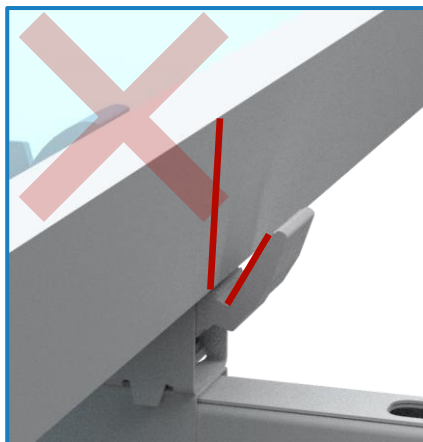

Module and Cam have a large non-uniform gap.

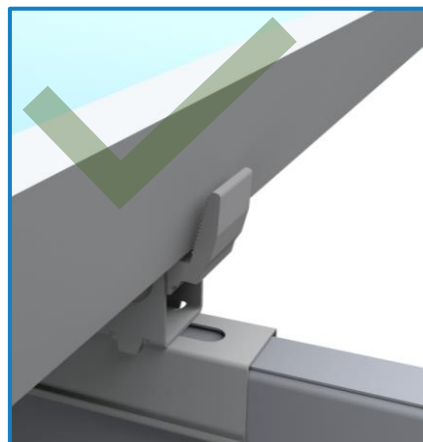

Module and Cam are near flush.

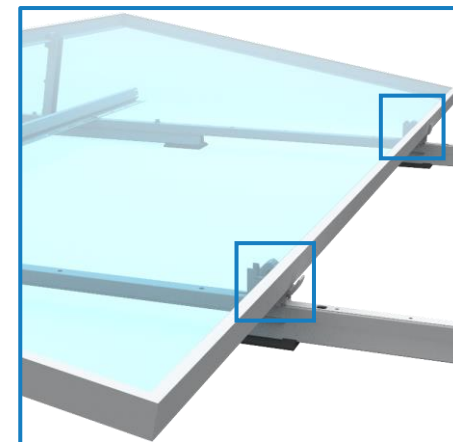

Lock Claw Insertion Gauge configuration and use

Select a Lock Claw which has been confirmed to be installed correctly through visual inspection.

The Tilt Arm and Lock Claw should be aligned with the module frame and the Lock Claw fully engaged on the frame.



Place gauge against Lock Claw and underside of module.



Mark line on gauge to finish setup.

Use gauge to confirm full Lock Claw engagement-line must be visible.

Electrical Grounding

Please consult with national and local building code(s) for complete grounding requirements for your installation. The clawFR grounding method conforms to ANSI/UL 2703 and is certified by Intertek for use with approved photovoltaic modules listed under ANSI/UL 1703 and/or ANSI/UL 61730. Installers can quickly and easily establish ANSI/UL 2703 certified electric bonds between all connected array components, including modules and mounting system components, without the use of additional grounding devices, e.g. ground lugs and copper wire. At least one ground lug must be used to ground all strings within a physical sub-array provided the fuse rating for each string does not exceed 40 amps. Installers may opt to use multiple lugs per sub-array for redundancy. When grounding devices are installed according with the approved methodology and capacity, the connections described above meet all the requirements outlined in NEC 690.43.

Grounding Instructions

For modules that have been evaluated for use with clawFR 5 Degree, please follow the instructions below in [Appendix A: UL 2703 Grounding](#). Additional information regarding ANSI/UL 2703 and the specific list of evaluated modules included in PanelClaw's UL 2703 listing can be found in the "clawFR/clawFRplus UL 2703 List of Ratings and Compatible Modules and MLPEs". The most recent version is available on the PanelClaw website (www.panelclaw.com/ul-2703).

For modules that have not been evaluated for use with clawFR, please contact PanelClaw.

ALERT: During grounding and bonding ensure there is separation between bare copper and aluminum or coated steel components.

Appendix A: UL 2703 Grounding

The clawFR 5 Degree flat roof system may be used to ground and/or mount a PV module complying with ANSI/UL 1703 or ANSI/UL 61730 only when the specific module has been evaluated for grounding and/or mounting in compliance with the included instructions. For a list of modules which have been evaluated see PanelClaw’s “clawFR/clawFR*plus* UL 2703 List of Ratings and Compatible Modules and MLPEs”. The most recent version can be found on the PanelClaw website (www.panelclaw.com/ul-2703).

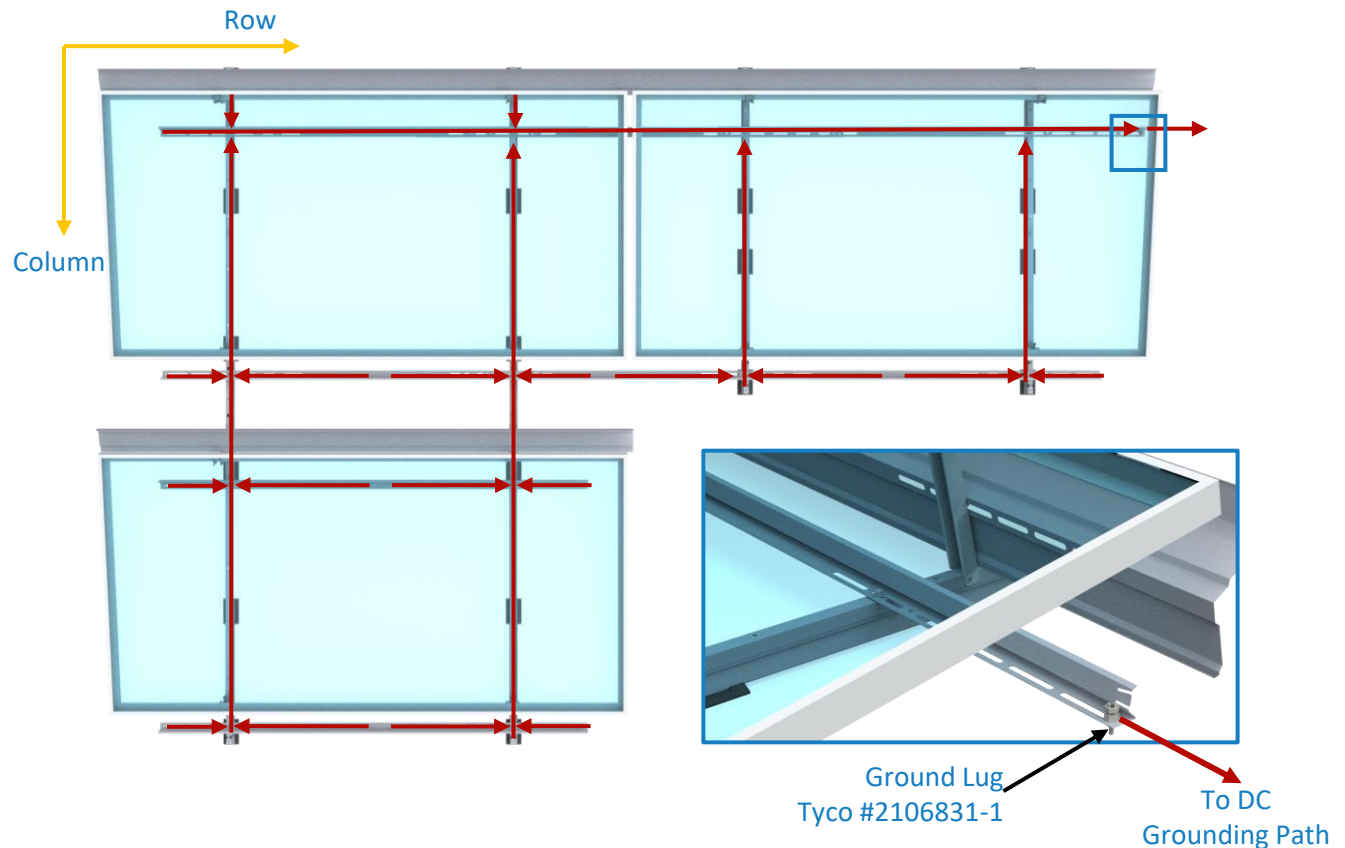

System Ground Path

The system ground path “grid” is established throughout the array by the interconnection of system components. Specifically, in the column direction via the Base and Module Connector connections and in the row direction via the Rail connections. A Tyco lug connected to the Rail establishes a point of connection for the EGC at one location with a contiguous array. All modules are grounded to the system through their Cam to Module connection.

Note: The presence of a PV module does not affect the bonding ability of the clawFR system components. More precisely, the grid provides a means to ground PV Modules which have been evaluated for ANSI/UL 2703 grounding with clawFR.

Appendix A: UL 2703 Grounding (Continued)

Grounding Instructions:

PanelClaw components within the array are required to be electrically bonded to other DC grounding paths via the use of appropriately sized Cu wire and a UL 467 listed Tyco Solarlok grounding assembly, part number **2106831-1**, manufactured by Tyco Electronics Corporation. The conductor size should be selected in accordance with NEC 690.45 and NEC 250.122.1.

To ground the array, first determine the groupings of strings whose power output wiring is grounded together at an equipotential grounding conductor location. This could be all the strings within a physical sub-array, or all the strings grouped by a single combiner box. Once the groupings of strings at equipotential have been determined, a Tyco solid wire grounding assembly must be attached to one Rail within each group of strings. PanelClaw's clawFR Rails have a hole to which this grounding device/lug can be attached. In an array that requires multiple bonding jumpers to satisfy the equipotential requirements, each bonding jumper should be located and installed on a Rail within the group of strings which will be grounded by that jumper.

ALERT: Every sub-array must include at least one grounding device/lug.

Tyco Grounding lug attachment:

To attach the Tyco grounding device/lug to the Rail, the mounting hex washer and threaded post end should be installed to the specified hole in the Rail and torqued to **2.08 ft-lb (25 in-lb)**. Once the grounding device/lug has been attached to the Rail, a copper bonding jumper from an acceptable DC grounded location outside of the array must be installed to the wire slot end and torqued to **3.75 ft-lb (45 in-lb)**. For additional instruction regarding the installation of the Tyco solid wire grounding assembly, please refer to the Tyco Electronics instructions sheet (document number 408-10262) via their website www.te.com.

ALERT: If installing clawFR 5 Degree with a module which is not on the UL2703 listing, contact PanelClaw.

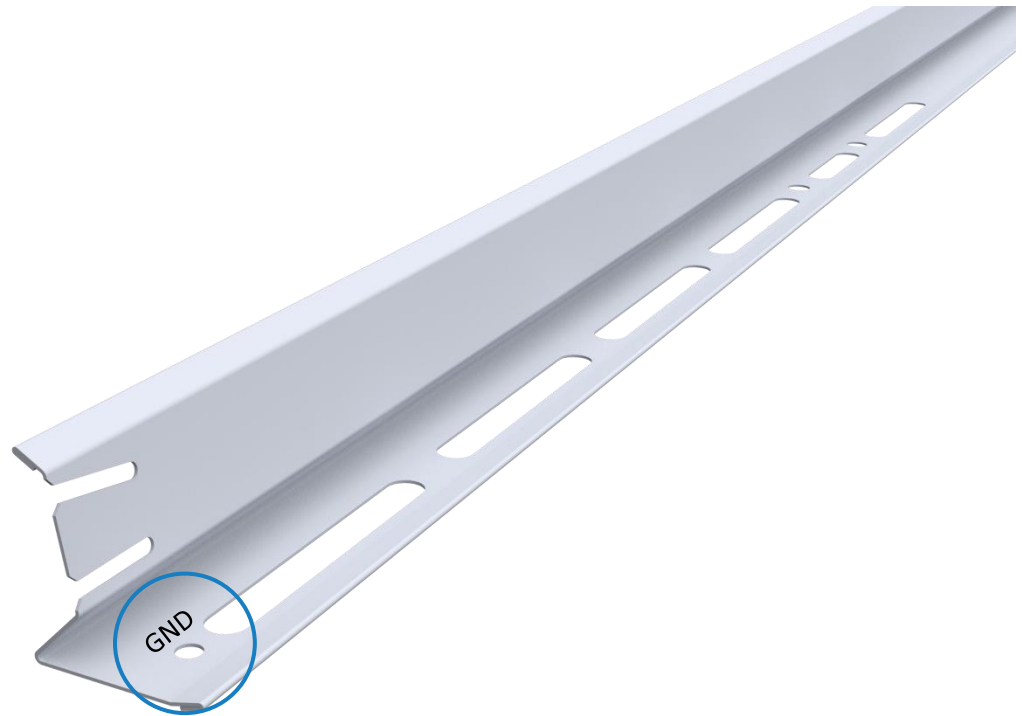

Appendix B: Ratings

UL 2703 Listing:

ClawFR 5 Degree Conforms to UL STD 2703 (2015) Standard for Mounting Systems, Mounting Devices, Clamping/Retention Devices, and Ground Lugs for Use with Flat-Plate Photovoltaic Modules and Panels and Certified to CSA TIL No. A-40.

- Max Overcurrent Protective Device (OCPD) Rating: 40A
- Max Module Size: 36.8 ft²
- Module Orientation: Landscape
- System Design Load Rating: 30psf downward, 30psf upward, 5psf lateral
- Actual system structural capacity defined by the PE stamped calculation package and racking construction set

Fire Rating:

The cFR system has a CLASS A SYSTEM FIRE RATING PER UL 2703

- Low Slope Roofs (less than 2:12) with Module Types 1, 2, 16, 19, 22, 25, 29, 30 and 38
- Class A fire rating is applicable with or without wind deflectors. Review PanelClaw Racking Construction Set for deflector configuration requirements.
- Class A rated PV systems can be installed on Class A, B, and C roofs without affecting the roof fire rating.

UL 3741 Listing:

ClawFR 5 Deg Conforms to ANSI/CAN/UL STD 3741 (2020) Standard for Safety Photovoltaic Hazard Control System

- Refer to clawFR UL 3741 PV Hazard Control Installation Addendum for full ratings, approved equipment, components, and installation requirements.

Appendix C: Ballast Blocks

PanelClaw does not provide the ballast blocks required to construct the system in accordance with PanelClaw’s Racking Construction Set drawings.

Ballast blocks for any ballasted rooftop system shall conform to ASTM C1491 or C1884 where applicable. Under these standards, ballast blocks **MUST** be manufactured and tested for freeze-thaw durability. In locations where the quantity of freeze-thaw cycles is less than 25 (see figure below), ASTM C90 standard ballast blocks may be used. Please note the additional block specifications below which may be more stringent than the ASTM specification. It is strongly recommended that installers weigh several blocks on-site to ensure block weights match what is specified on PanelClaw’s Racking Construction drawings.

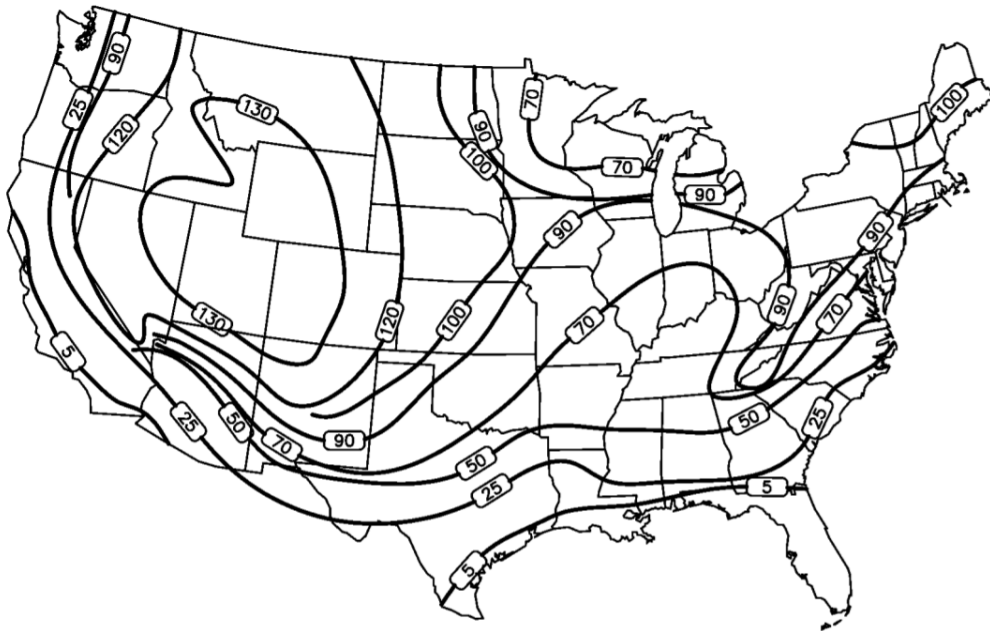

Approximate Number of Freeze-Thaw Cycles Per Year

Minimum Ballast Block Specification		
ASTM Standard	C1491 & C1884	C90
Min. Compressive Strength	2500 psi	2000 psi
Min. Density	125 pcf	125 pcf
Max. Water Absorption	13 psf	13 psf



Ballast Block Description	Nominal Weight* lb [kg]
BLOCK, CONCRETE, 2"X 8"X 16"	14.6 [6.6]
BLOCK, CONCRETE, 3"X 8"X 16"	23.6 [10.7]
BLOCK, CONCRETE, 4"X 8"X 16"	32.6 [14.8]

*Tolerance = ± 5% Nominal Weight

Appendix D: Mechanical Attachment (“MA”) Strut

Part Number: 5000423 & 2000930/2000830

Tools Required:

Drill with In-Line Torque Limiter or torque wrench

Various sockets (see table)

ALERT: NO IMPACT DRIVERS

Torque Setting*	Fastening Operation
21 ft-lb (29 Nm)	U-bracket EZ connections (3/8” bolts)
6 ft-lb (8.1 Nm)	Mechanical Attachment Strut to Base connection

Socket sizes	Fastening Operation
10 mm Magnetic	Used with 6 mm bolts
9/16”	Used with 3/8” bolts

* +/-4% allowable during installation

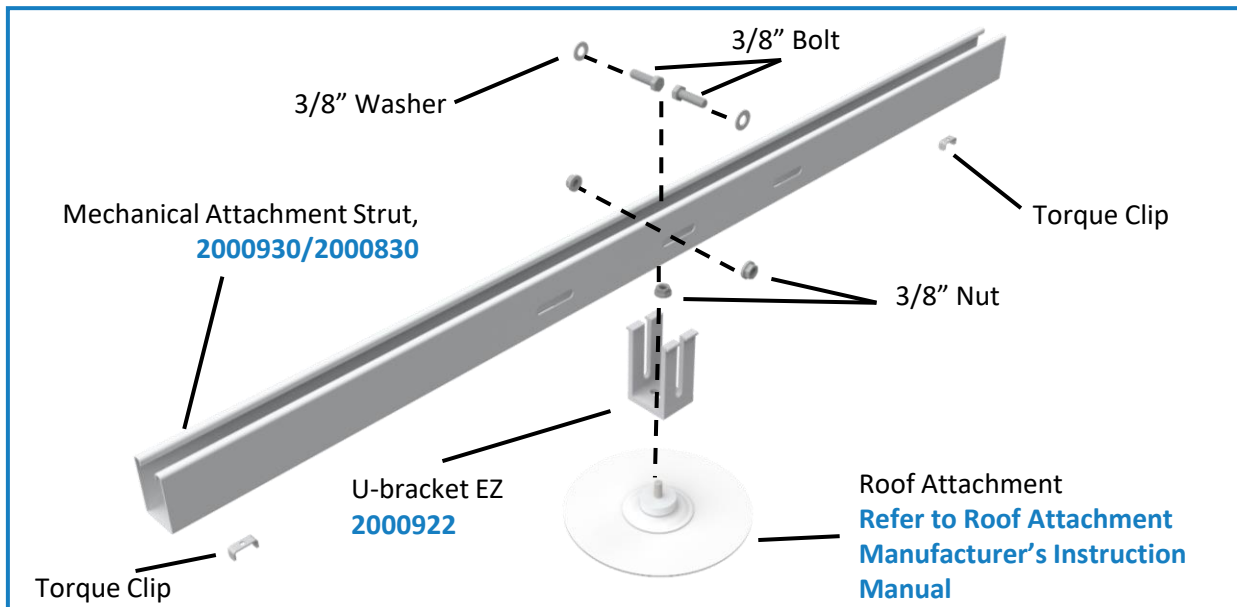

Step 1. Assemble template for components as shown, loosely assemble the U-bracket EZ and MA Strut with the necessary hardware as shown.

Tip: All hardware is included with **5000423 (MA Hardware Kit)**

Tip: Install MA’s after grid assembly is completed (prior to installing modules and deflectors).

Appendix D (Continued)

Part Number: 5000423 & 2000930/2000830

Step 2. Center Strut assembly between Bases at required install location. With a felt marker or other means **Mark** location of Roof Attachment in center slot of U-bracket EZ. **Install** Roof Attachment per manufacturer instructions.

Note: Image shows roof markings at low edge of module, process is the same for all MA installation locations.

Tip: Use off-center slots on the MA Strut if roof obstructions prevent the use of center slot.

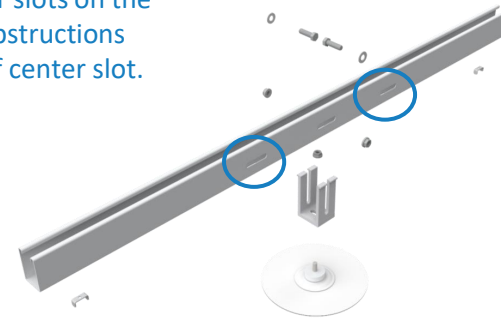

ALERT: See Sheet Title: Ballast Layout –XX in the Racking Construction Set for installation locations of Mechanical Attachments on each individual project.

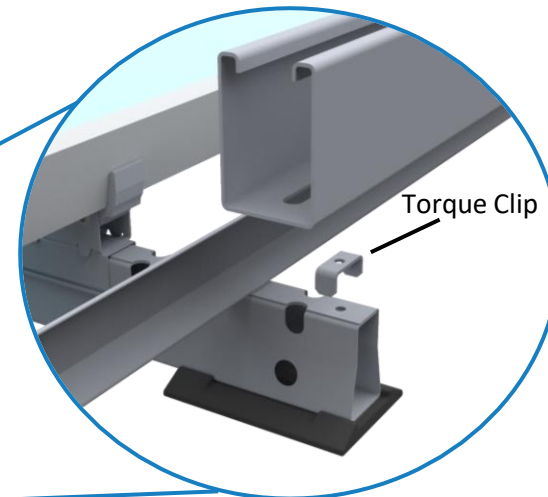
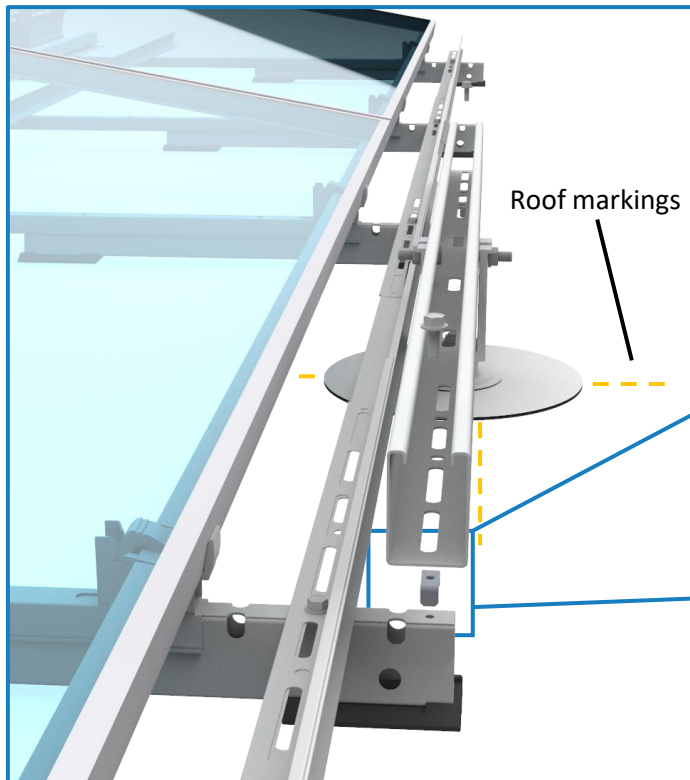

Torque Clip is fitted over the pilot holes on the Base. MA Strut is then aligned with the Torque Clip and Pilot hole before being secured by an M6 Bolt.

Appendix D (Continued)

Part Number: 5000423 & 2000930/2000830

MA Struts may be installed in several possible array locations.

ALERT: See Sheet Title: Ballast Layout –XX in the Racking Construction Set for installation locations of Mechanical Attachments on each individual project.

Step 3. Install U-bracket EZ to MA Attachment using 3/8" nut provided and tighten. Install torque clips onto the Bases and align with pilot holes. Place MA Strut in center of U-Bracket EZ and align slots with torque clips. Tighten remaining connections as shown.

Tip: Tighten M6 Bolt Connections before tightening 3/8" connections to Roof Attachment.

Interior Location (Typical)

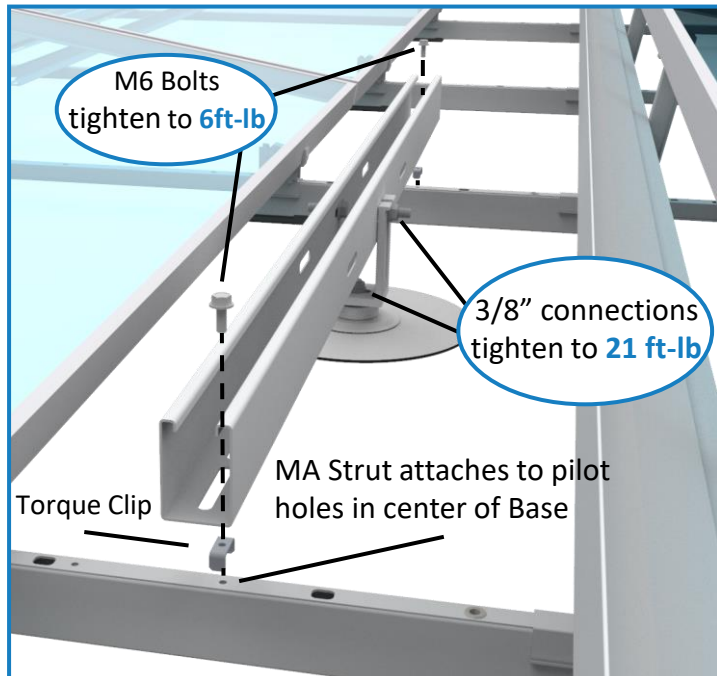

High Edge Installation Location (Typical)

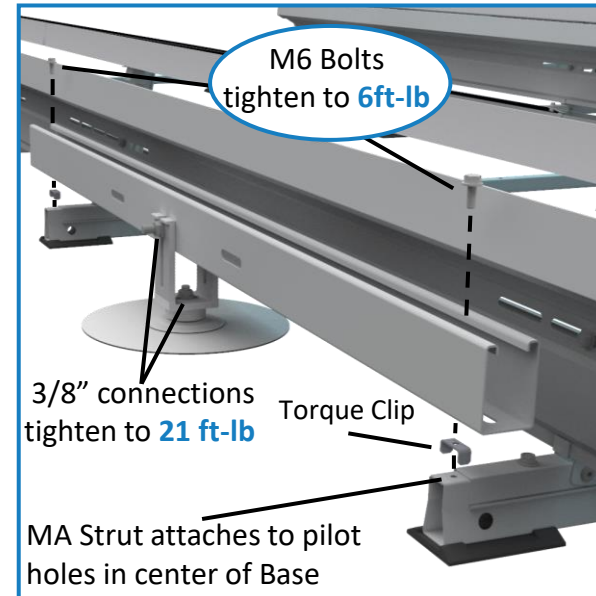

Low Edge Location (Typical)

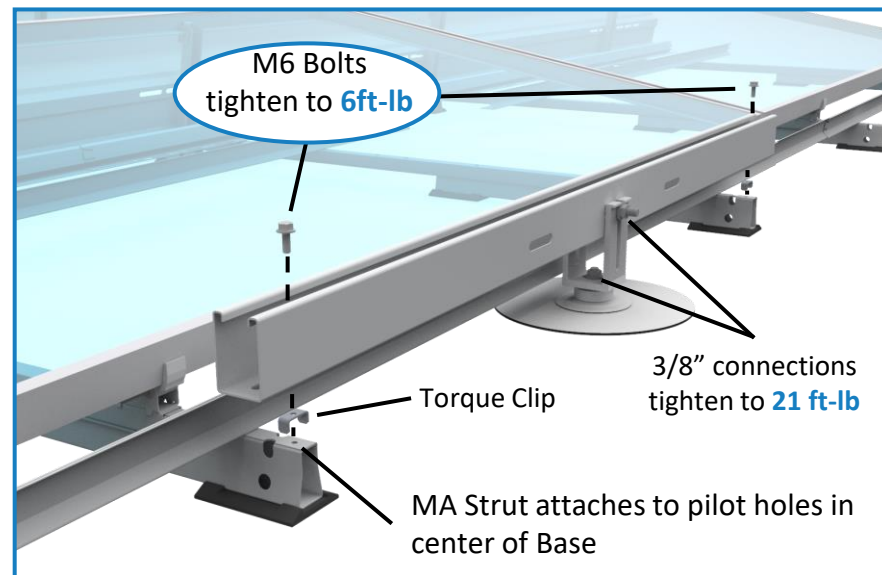

Appendix E: Shim Pad

Part Number: 5000228

Some roof systems with slope changes and/or localized undulations may result in cases where the Base Pads are more than 2" off the roof after array grid construction (prior to ballast, module, and deflector installation). If this occurs Shim Pads can be provided and installed on the bottom of the Base Pads to ensure the Base rests on the roof at all contact points.

Each **Shim Pad Pack** includes a total of 50 Shim Pads.

Alert: Shim Pad's can not be used to raise an entire array.

Cones nest into holes in Base Pad

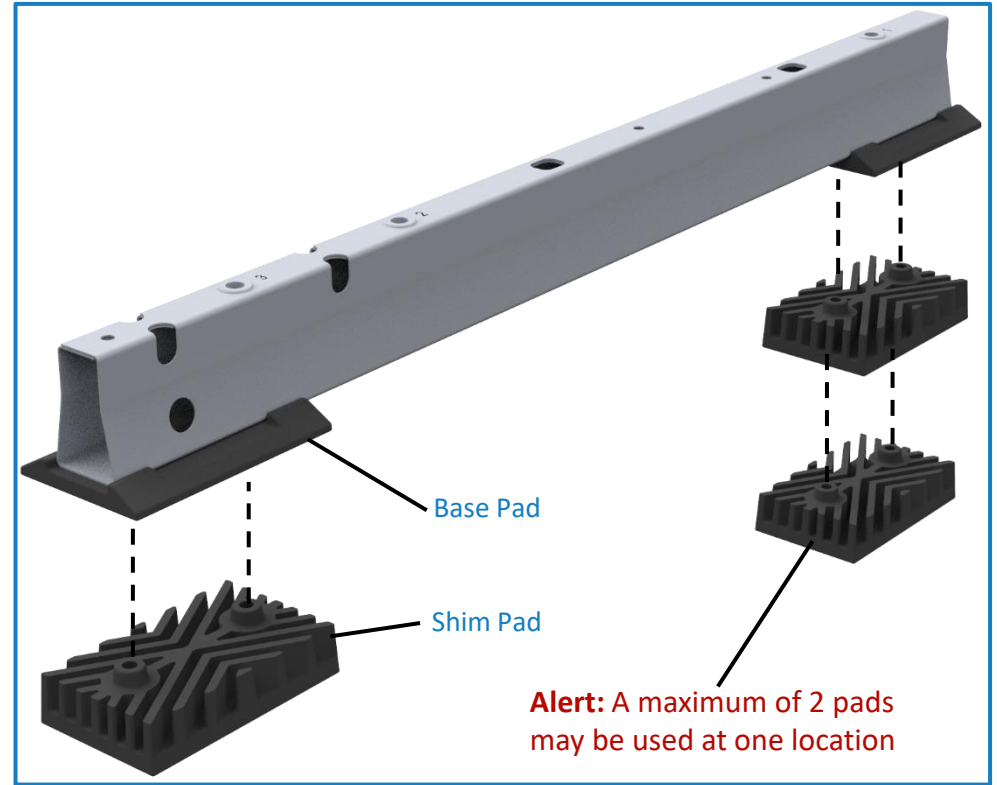
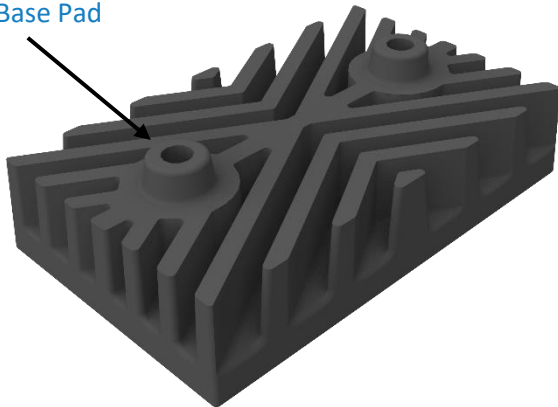

Place the Shim Pads underneath the Base Pads and press firmly.

Tip: Use one or two Shim Pads as shown to ensure each Base rests on the roof at all contact points.

Appendix F: Base Pad

Part Number: 2000678

Some roof systems may need to disperse the concentrated loads of the arrays over more surface area. If this is the case, additional Base Pads can be provided and installed into additional slots on the bottom of the Bases to increase the load distribution to the roof.

Base Pads should be installed during the “Step 2. Build Assemblies” for clawFR systems.

Each **Base Pad Pack** includes a total of 350 Base Pads.

ALERT: See Sheet Title Page: Ballast Layout –XX in the Racking Construction Set for installation locations of Base Pads on each individual project.

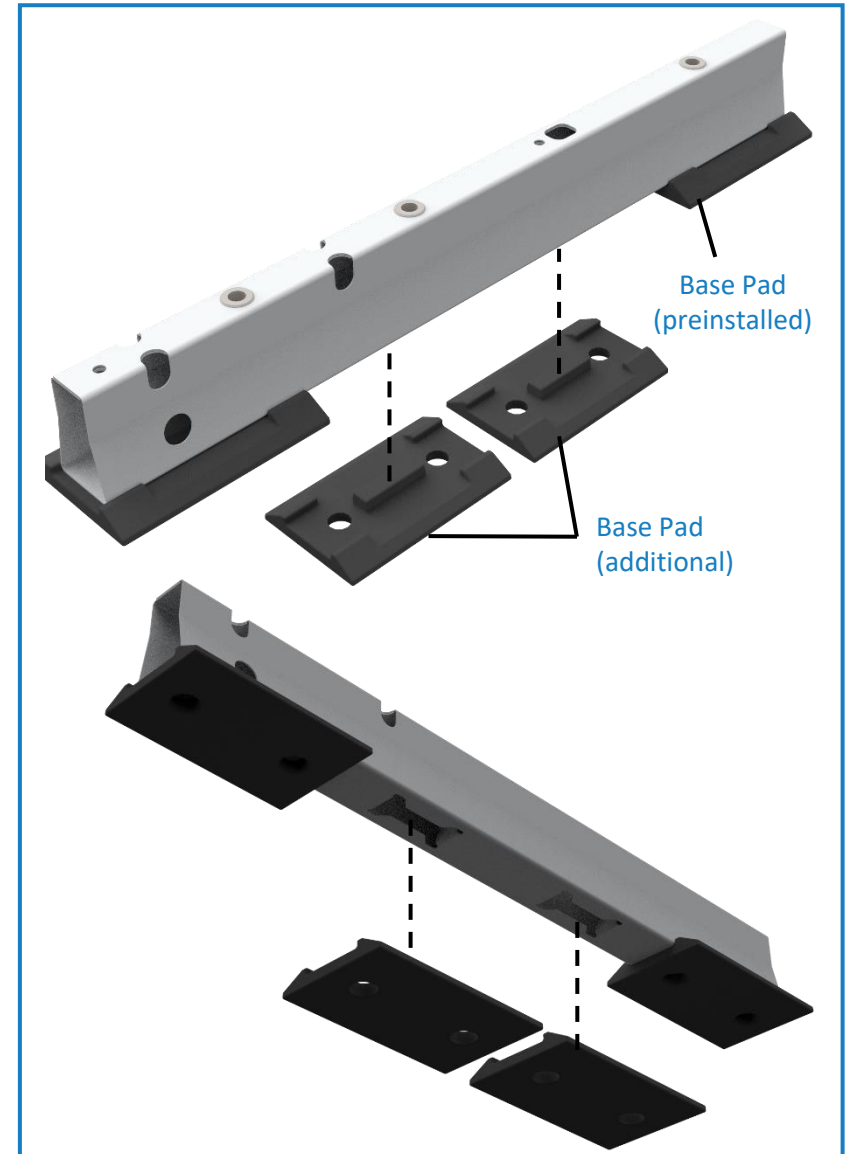
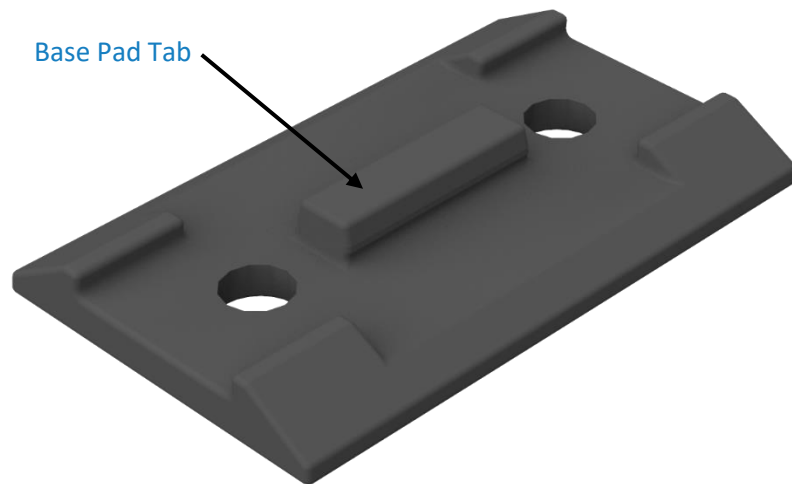

Press Base Pad Tab into slot on Base.

Note: The quantity of slots may vary depending on the Base version.

Appendix G: MLPE Bracket

Part Number: 5000519

Module Level Power Electronics (MLPE) provide a host of benefits to solar arrays. The MLPE bracket offers a convenient solution for mounting MLPE's to clawFR 5 Degree system.

Each **MLPE Bracket Kit** includes the following items (sufficient for mounting 100 MLPEs to clawFR)

- 100 - MLPE Bracket
- 100 - 5/16" Flange nut
- 100 - 5/16" Bolt
- 100 - M6 Bolt

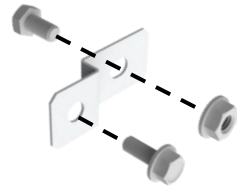

Tools Required:

Drill with In-Line Torque Limiter or torque wrench

Various sockets (see table)

ALERT: NO IMPACT DRIVERS

Torque Setting*	Fastening Operation
3 ft-lb (4.1 Nm)	MLPE Bracket to clawFR system components
6 ft-lb (8.1 Nm)	MLPE to MLPE Bracket and as specified

* +/-4% allowable during installation

Socket sizes	Fastening Operation
10 mm Magnetic	Used with 6 mm bolts
1/2"	Used with 5/16" bolts

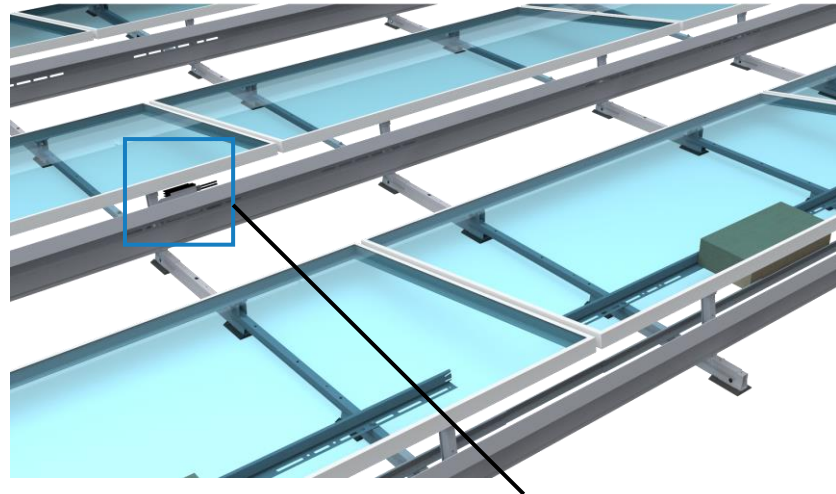

MLPE is optimally located near two adjacent modules

The **MLPE Bracket** is UL 2703 approved for bonding. A specific list of compatible MLPEs can be found in the "clawFR/clawFRplus UL 2703 List of Ratings and Compatible Modules and MLPEs" document. The most recent version is available on the PanelClaw website (www.panelclaw.com/ul-2703).

ALERT: 5/16" bolts are used for MLPE installation. Check MLPE installation manual for specific instructions.

Appendix G: SolarEdge Installation

Part Number: 5000519

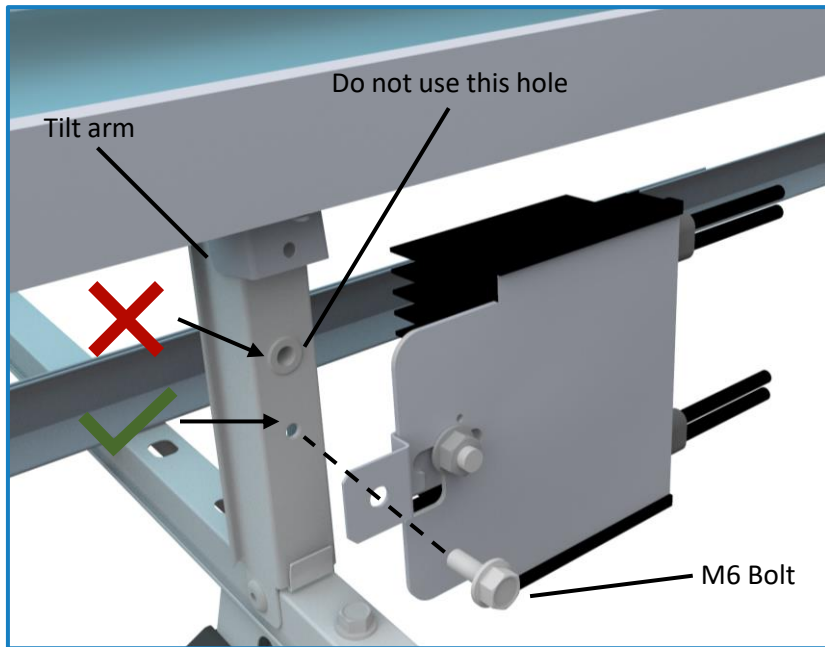

Attach MLPE to Tilt Arm using M6 bolts. Torque to **3 ft-lb**.
 Attach MLPE Bracket to MLPE Mounting Plate using 5/16" bolt and Torque to **6ft-lb**.

Tip: Preassemble the MLPE Bracket to the MLPE prior to attaching to the system.

Tip: Install MLPE to Tilt Arm before installing the module.

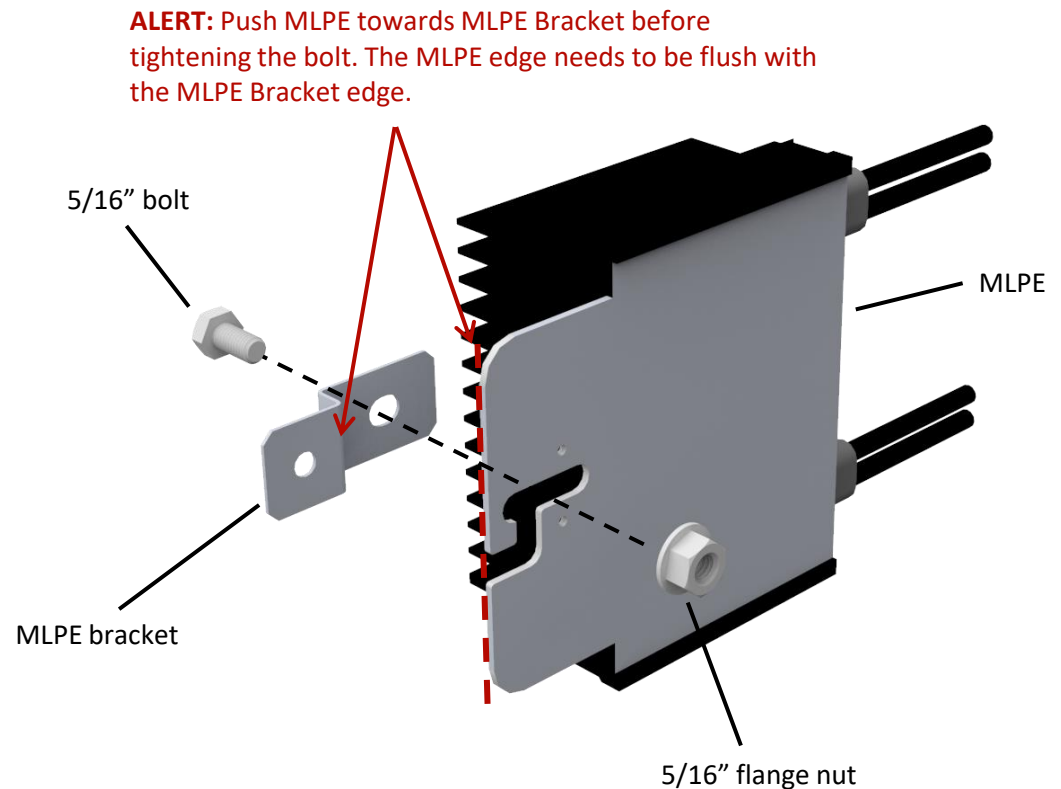

Appendix G: Tigo Energy Installation

Part Number: 5000519

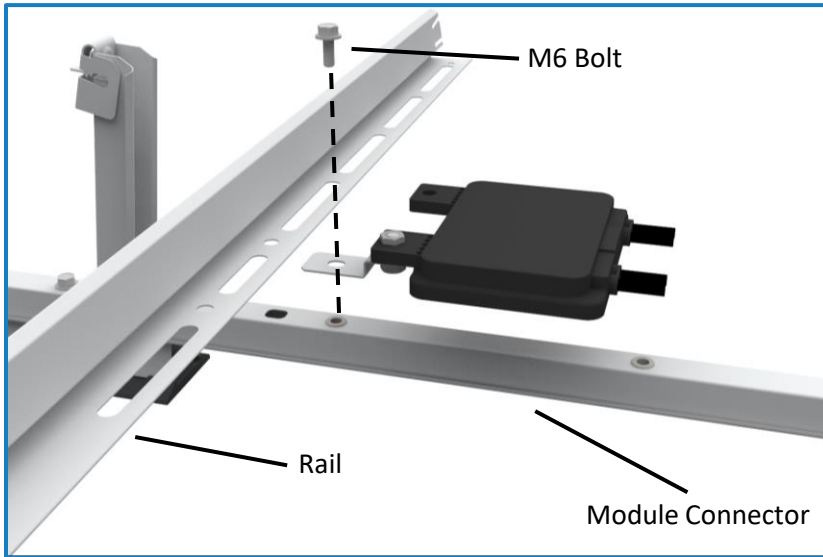

Attach MLPE to Module Connector underneath the rail using M6 bolts. Torque to **6 ft-lb**.

Attach MLPE Bracket to MLPE Mounting Plate using 5/16" bolt and Torque to **6 ft-lb**.

Tip: Preassemble the MLPE Bracket to the MLPE prior to attaching to the system.

Tip: Install MLPE to Module Connector before installing the module.

ALERT: In this orientation the Tigo MLPE is attached to the hole and not the slot in the MLPE Bracket

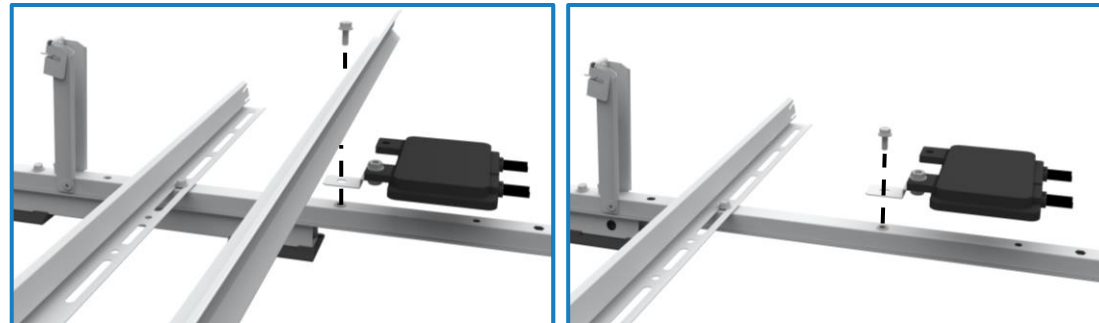
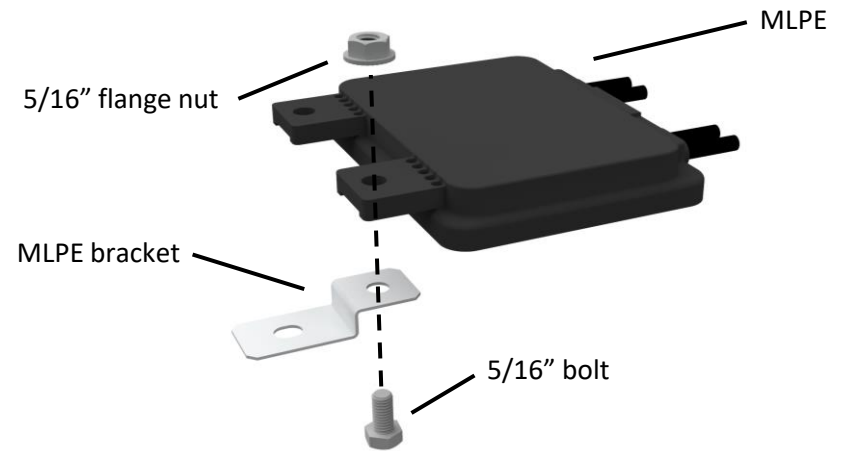

Alternative mounting locations under the ballast rail or directly to the pre-installed nut are also accepted.

Appendix G: Enphase Energy Installation

Part Number: 5000519

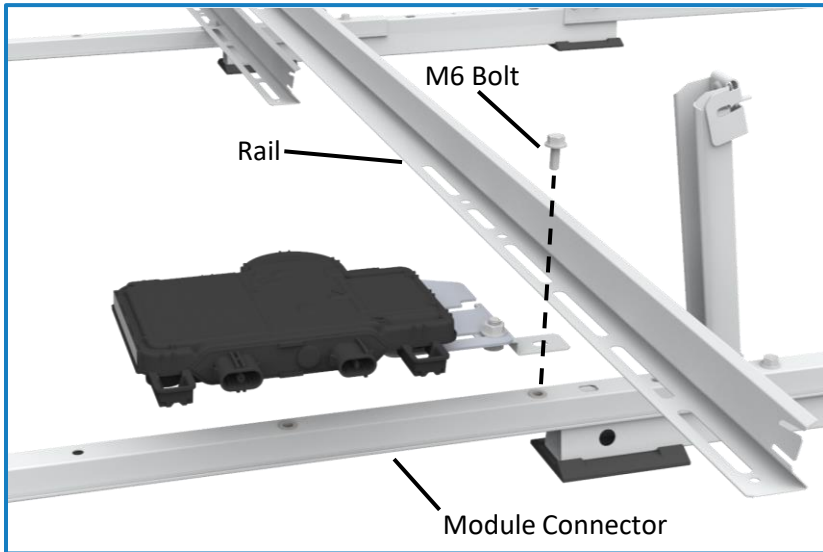

Attach MLPE to Module Connector underneath the rail using M6 bolts. Torque to **6 ft-lb**.

Attach MLPE Bracket to MLPE Mounting Plate using 5/16" bolt and Torque to **6 ft-lb**.

Tip: Preassemble the MLPE Bracket to the MLPE prior to attaching to the system.

Tip: Install MLPE to Module Connector before installing the module.

ALERT: In this orientation the Enphase MLPE attaches to the hole and not the slot in the MLPE Bracket

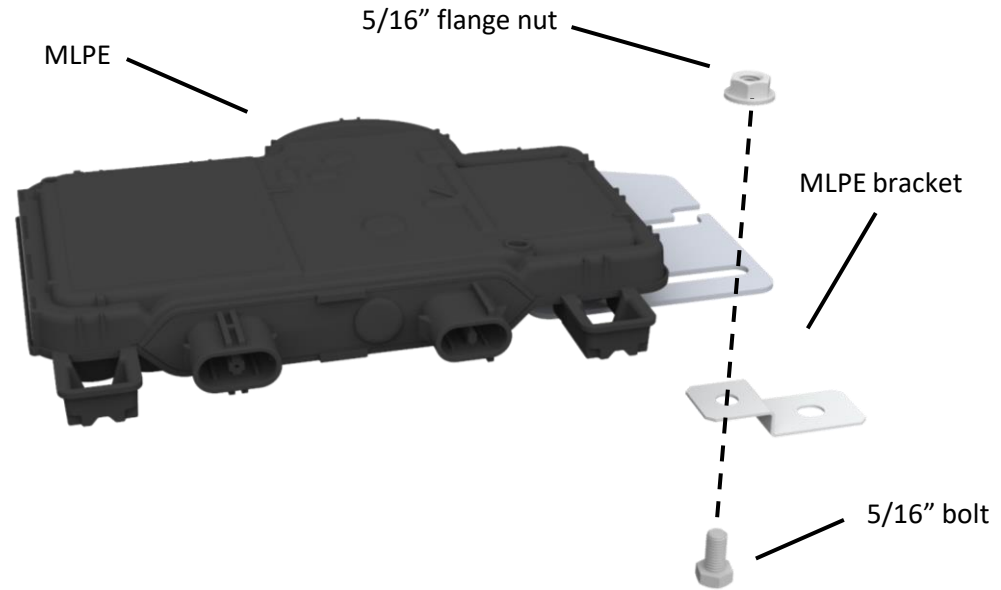

ALERT: MLPE must be a minimum of 3" away from the roof, and at least 1.5" from the back sheet of the module.

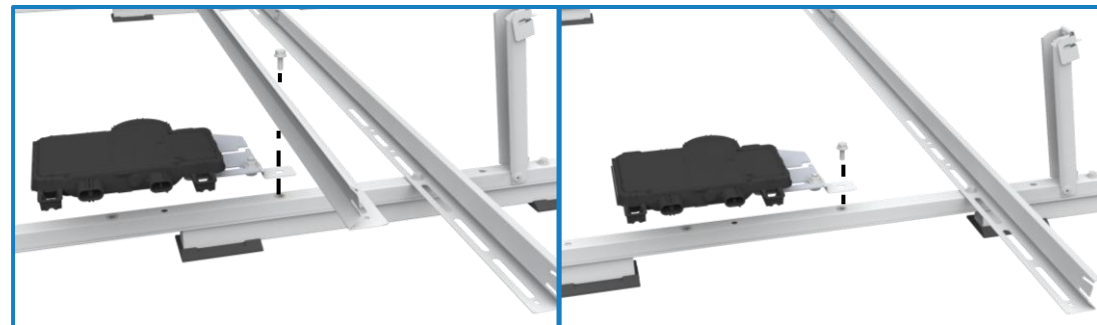

Alternative mounting locations under the ballast rail or directly to the pre-installed nut are also accepted.

Appendix H: Lock Claw Clip

Part Number: 2000819/5000419

Lock Claw Clips are a part of the module adapters that will be included with your order in such cases that modules require it.

Each **Lock Claw Clip Pack** includes 300 Lock Claw Clips.

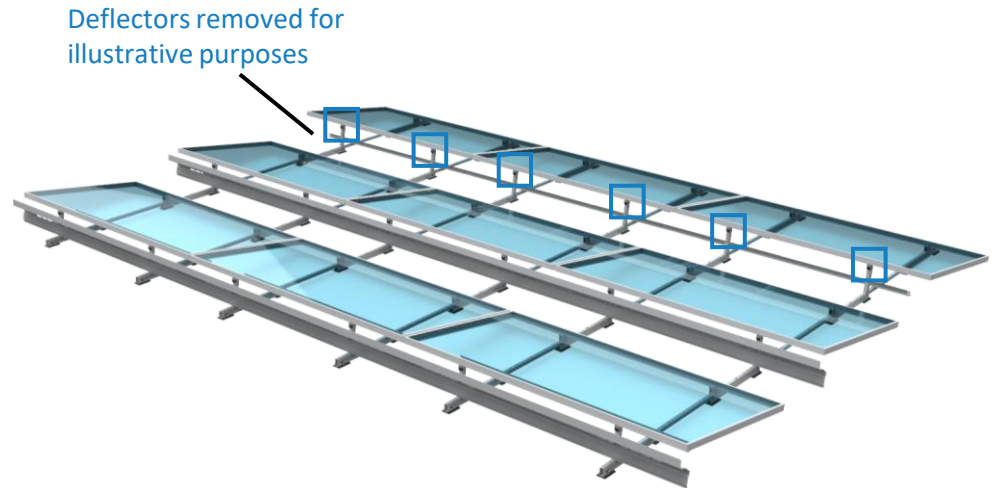

Tip: Lock Claw Clips are installed in every Lock Claw (2/module)

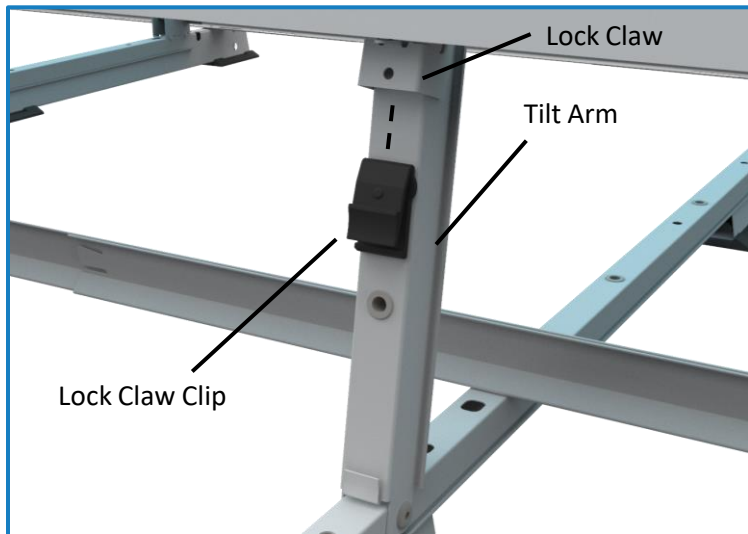

Lock Claw Clips are to be installed after installation of modules. Install the Lock Claw Clip by inserting the Lock Claw Clip into the gap between the Tilt Arm and the Lock Claw. Push up on Lock Claw Clip until it is fully inserted into the Lock Claw.



cFR 10D is depicted. Installation is the same for cFR 5D.

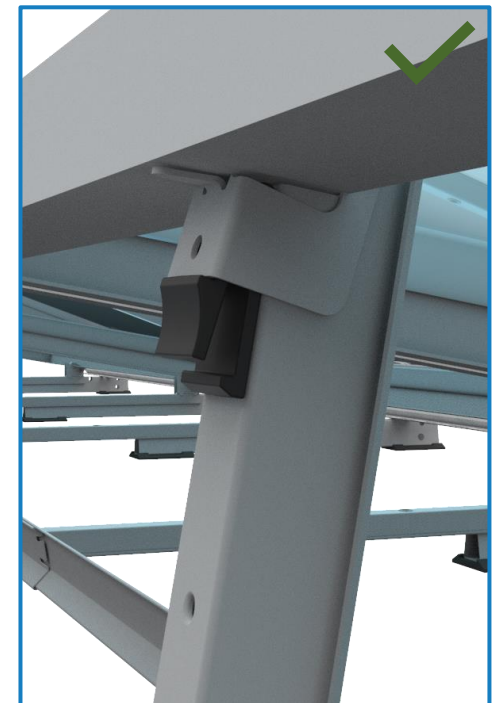

Example of typical good Lock Claw Clip Installation.

Appendix I: Frame Enhancer

Part Number: 2000832/5000532

Frame Enhancers are a part of the module adapters that will be included with your order in such cases that modules require it.

Each **Frame Enhancer Pack** includes 300 Frame Enhancers.

ALERT: Verify that the slot of the frame enhancer is aligned with the module frame

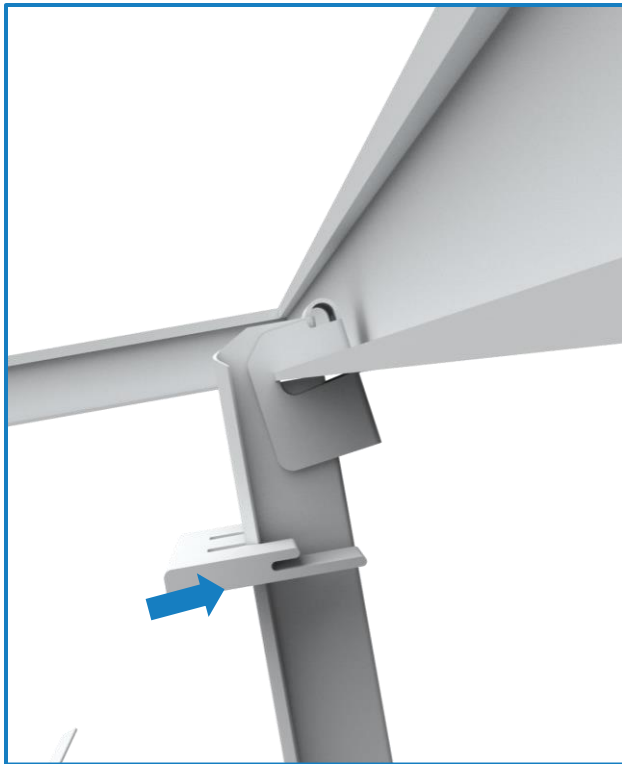
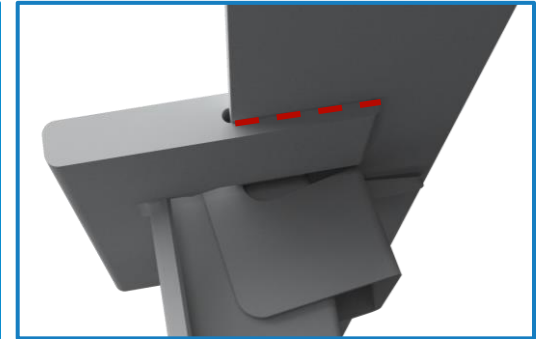
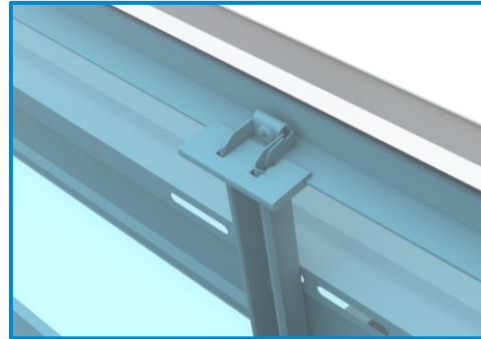

Align the Frame Enhancer with the Tilt Arm



Slide the Frame Enhancer along the Tilt Arm. Stop when the Frame Enhancer is in contact with the bottom of the module flange.



Pull the Frame Enhancer until it clicks into the tilt arm.

Appendix J: Cam Seat Spacer – Installation Aid

Part Number: 2000833/5000533

Cam Seat Spacers are a part of the module adapters that will be included with your order in such cases that modules require it.

Each **Cam Seat Spacer Pack** includes 300 Cam Seat Spacers.

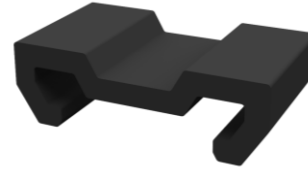

Tip: Install Cam Seat Spacer when assemblies are being built

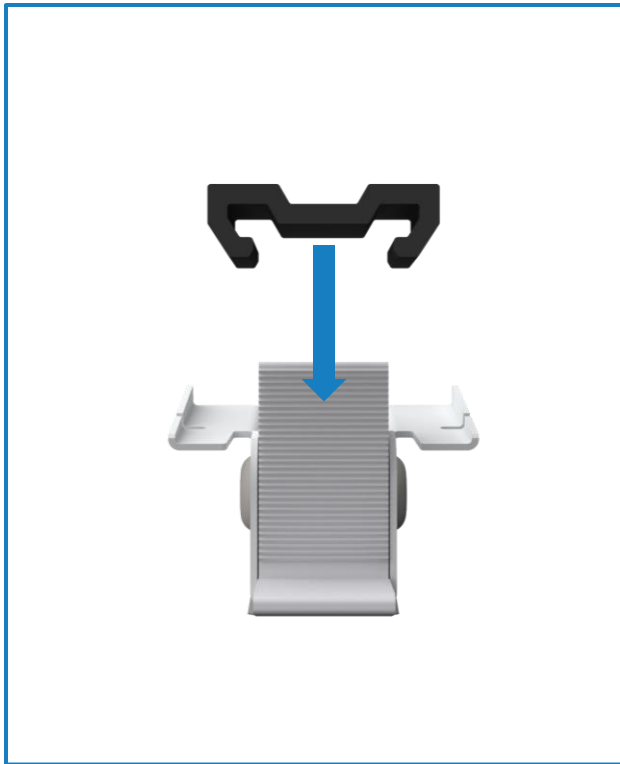

Align the Cam Seat Spacer with the Cam Seat



Click the Cam Seat Spacer onto the bottom of the Cam Seat.

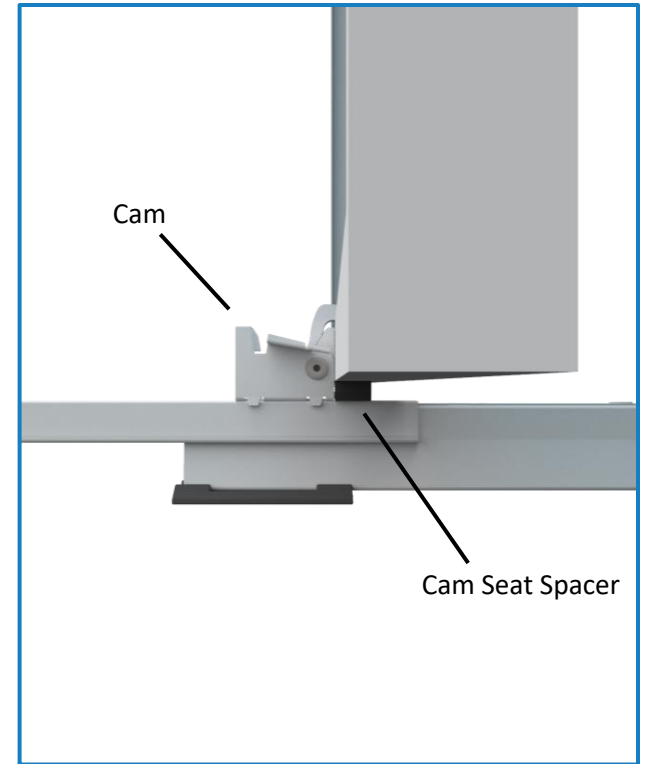

During module installation modules will sit on the Cam Seat Spacer. Follow step 6 on page 14 in the installation manual to install modules as normal.

Appendix K: Lock Claw Reset Method

In rare cases, Lock Claw performance can be degraded by damage from improper handling or excessive cycling.

If the Lock Claw angle relative to the Tilt Arm is outside the specified range of 8 to 10 degrees, follow the steps below to reset the Lock Claw.

Place a finger or a suitable tool between the Lock Claw and Tilt Arm then slowly open the gap.

Adjust the gap angle to about **8 to 10 degrees**.



ALERT: Do not bend the lock claw more than 20 degrees. Doing so may cause permanent damage

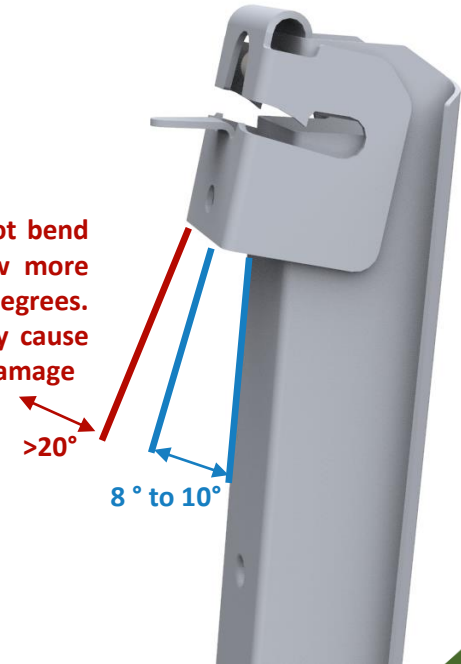

Appendix L: Safety

The subsections below outline some of the obvious / major hazards that could exist during the installation or O&M of PanelClaw products and are divided to bring a level of clarity to such hazards. Some sections do not apply to all PanelClaw product lines and such exclusions are noted within each section.

Electrical Hazards: PanelClaw products are purely mechanical and do not contain any electrically live parts. When a photovoltaic module is exposed to sunlight it is electrically live and cannot be turned off. As soon as modules are installed using a PanelClaw system, an electrical shock hazard is present. All personnel on site should coordinate to ensure that such electrical hazards are clearly communicated. It is advised, at a minimum, that all personnel utilize caution and proper Personal Protective Equipment as outlined in that section. Only electrically qualified personnel should perform PV module installation. Refer to OSHA Part 1926 Subpart K – Electrical and NFPA 70E for additional information.

Environmental Hazards: Look for hazards associated with water and snow loading if observed upon entry into the array area. Standing water increases the likelihood of electrical shock if the PV electrical system is compromised in any way. Severe snow loads can result in module and/or racking damage and, in extreme cases, electrical hazards.

Fall Hazards: This section only applies to clawFR[®] products installed on locations six feet or higher above grade. Proper fall protection should be in place at all work sites. There are many fall protection solutions readily available to help reduce exposure to fall hazards. These may include personal fall arrest systems, safety nets, guardrails, and flagged setbacks from all roof edges as outlined in OSHA Part 1926 Subpart M – Fall Protection.

Trip Hazards: All PanelClaw arrays have elevated components that are installed above grade or above a roof surface. Such hazards should be identified and caution should be taken to avoid tripping over such components. Refer to the Fall Hazards section specifically if working with the clawFR product line. Make sure to pick up and not drag your feet when working on site, and always pay attention to your path of movement to note any obstructions that could create a trip hazard.

Lifting Hazards: The PanelClaw installation process involves lifting of heavy items that could lead to personal injury and damage to property. All personnel should be trained in the proper procedures for manually lifting. Evaluate an object's size and weight prior to lifting, and follow these general guidelines for lifting:

1. Assess the lift and know the object weight.
2. Bend at the knees and get a good grip.

Appendix L: Safety (Continued)

3. Keep back straight and lift straight up with legs without twisting. It is important to lift with the legs and not the back.
4. If an object is too large or heavy, ask for help and do not attempt to lift by yourself. In the case that mechanical assistance (e.g. crane, forklift, etc.) is required to complete the lifting operations, all machine operators of such devices should be licensed and trained.

Material Handling: All PanelClaw parts and components are made of aluminum and steel alloys and utilize stainless steel assembly hardware. These materials are considered non-toxic and require no special handling procedures. Metal components may have sharp edges, so be sure to handle with care and utilize proper personal protection equipment, especially gloves, during handling. Refer to OSHA Part 1926 Subpart H – Materials Handling, Storage, Use, and Disposal for additional information.

Personal Protective Equipment (PPE): All personnel should utilize and implement proper PPE per OSHA requirements. Refer to OSHA requirements for proper use and implementation of PPE. The following items are suggested as a minimum to avoid injury based on the installation procedure outlined in this manual:

1. Appropriate work clothing
2. Electrically insulated hard hat
3. Protective eyewear
4. EH rated safety boots
5. Gloves
6. High-visibility safety vest
7. Hearing protection

If any PPE appears to be defective, stop the use of such equipment immediately, and ensure it is replaced before work continues. Refer to OSHA Part 1926 Subpart E – Personal Protective and Life Saving Equipment for additional information.

Hand and Power Tools: Access to all hand and power tools should be regulated and controlled at all times on site to prevent improper use and related injuries. When not in use, all equipment should be stored in a secured location. Only personnel who have been properly trained in the safe operation of any potentially dangerous tool should be allowed access. All required tools to perform the installation of PanelClaw racking are outlined in the installation procedure. All tools should be inspected daily and before use by the operator. If any tool appears to be defective, stop the use of such equipment immediately, and ensure it is replaced before work continues. Electrical power tools should follow proper lock-out tag-out procedures per OSHA requirements. Refer to OSHA Part 1926 Subpart I – Tools – Hand and Power for additional information.