

clawFR Dual Tilt 10 Degree Assembly Jig

Why Build a Jig?

The clawFR installation manuals outline a process for constructing assemblies that consists of repeated use of the “Cam Spacer” (see page 7 of the clawFR Dual Tilt installation manual). Building an Assembly Jig will expedite construction of the assemblies and increase quality by eliminating the use of the cam spacer after template assemblies are made. All assemblies following the template assemblies can be made using the jig without use of the cam spacer.

Assembly Jig Components



2" x 4" x 12' Lumber



6' Extra Low-Profile
Strut Channel
[1259N18]

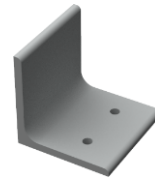

1/8" Thick 90 Degree
Angle
[9017K481]



No. 6, 1-1/2" Steel
Wood Screw
[9715A103]



1-1/4" Thick Wood
Block

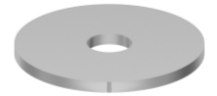

General Stainless-Steel
Washer for No. 6
Screw Size
[91525A103]

Note: The part numbers listed are sourced from McMaster-Carr. These are common parts that can be bought from a preferred vendor.

Note: All clawFR components necessary for the assemblies are supplied. For a list of these components see page 4 of the clawFR Dual Tilt instruction manual.

Alert: The components listed for the jig are not supplied.

Tools

- Power Drill
- No. 2 Phillips Driver
- 9/64" Drill Bit (Metal Rated)

Alert: See page 5 of the installation manual for the necessary tools and torque limits required to assemble the clawFR assemblies.

Build Assembly Jig

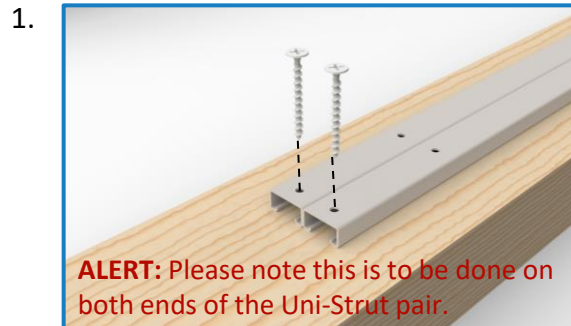

Take a piece of 2"x4"x12' lumber or equivalent. Place two 6' sections of Uni-Strut stock flat side face up, side by side on the plywood sheet for East and West Assemblies. For Middle Valley Assembly use four 6' sections of Uni-Strut stock. Drill two holes at each end of the Uni-Strut pair, fastening them to the two-by-four using drywall screw or other means.

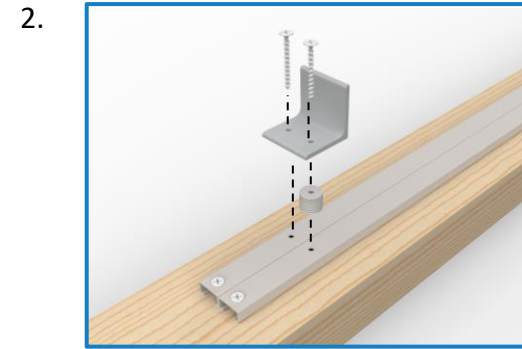

For each assembly, cut two pieces of 90-degree Angle stock to width of the Uni-Strut pairs, drilling two holes equal distance apart within center of Uni-Strut. Using an appropriate number of washers screw down through the 90-degree Angle into the two-by-four with drywall screw or other means.



Build an East, West, and Middle Valley assembly using the Cam dimensions provided within the Racking Construction Set. These assemblies will be used to set jig spacing.

ALERT: See "Build Assemblies" Section of the Dual Tilt cFR Installation Manual on how to properly assemble the East, West and Middle Valley Assemblies.



Place assembly onto the Uni-Strut Pair. Align the assembly so that one side of the end of the base is flush with the attached 90-Degree Angle. This Assembly will set the reference distance.

Alert: If the 90-Degree Angle is colliding with the Base Pad add more washers until the 90-Degree Angle clears the Base Pad.

Build Assembly Jig (Continued)

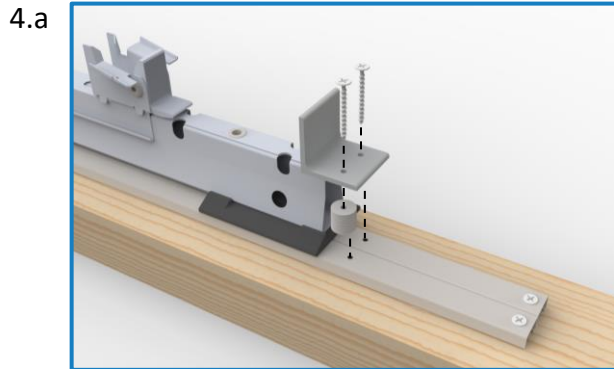

On the opposite end of the assembly repeat Step 2 to mount the second 90-Degree Angle to the two-by-four ensuring that the 90-degree angle is tightly flush with the base.

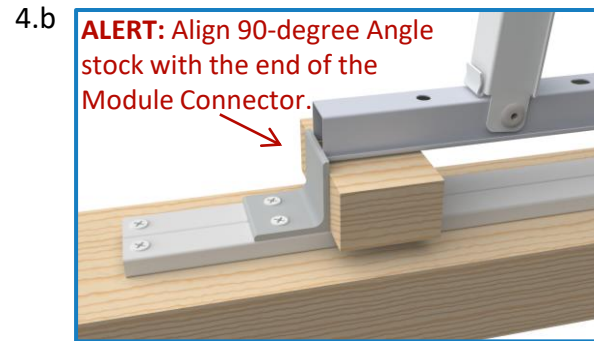

For West and Middle Valley Assemblies, cut a block of wood at 1.25" thick to the width of the Uni-Strut pairs. Place underneath Module Connector to keep assembly level opposite of the Base.

Tip: Wood block can be replaced with equivalent sized object.

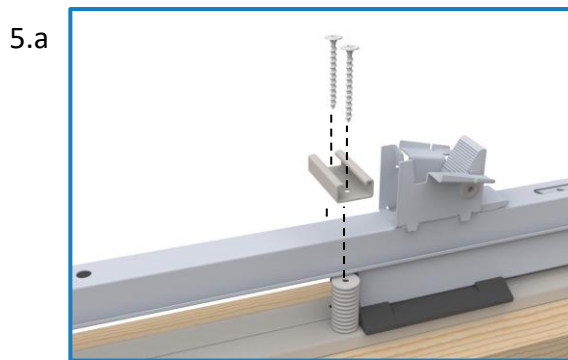

For Middle Valley Assemblies, cut a section of Uni-Strut Stock to the width of the Uni-Strut pair. Place underneath the Module Connector using an appropriate number of washers. Drill two holes in the Uni-Strut section and fasten to the Uni-Strut Pair using drywall screws or other means.

ALERT: Washers are used to align Uni-Strut with the Base and not the Base Pad

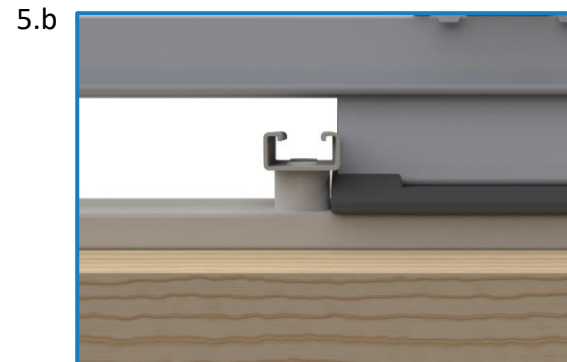

For Middle Valley Assemblies, ensure the Uni-Strut is aligned with the Base and not the Base Pad. If the strut is colliding with the Base Pad add more washers until it clears the Base Pad.

ALERT: Align Uni-Strut Section with the end of the Base

Build Assembly Jig (Continued)

Note: The size of the Uni-Strut Channels and the 90-Degree Angles, as well as the location of the drilled holes are not critical dimensions. What is important is the East-West spacing of the 90-Degree Angles. As long as East, West, and Middle Valley Template Assemblies are correctly assembled using the dimensions provided in the Racking Construction Set and the 90-degree angles are set flush to the assemblies then the jig can be used to construct all further assemblies.

ALERT: Metal components are being used due to the outside climate.

ALERT: Ensure Base is flush to the Sturt when building assemblies

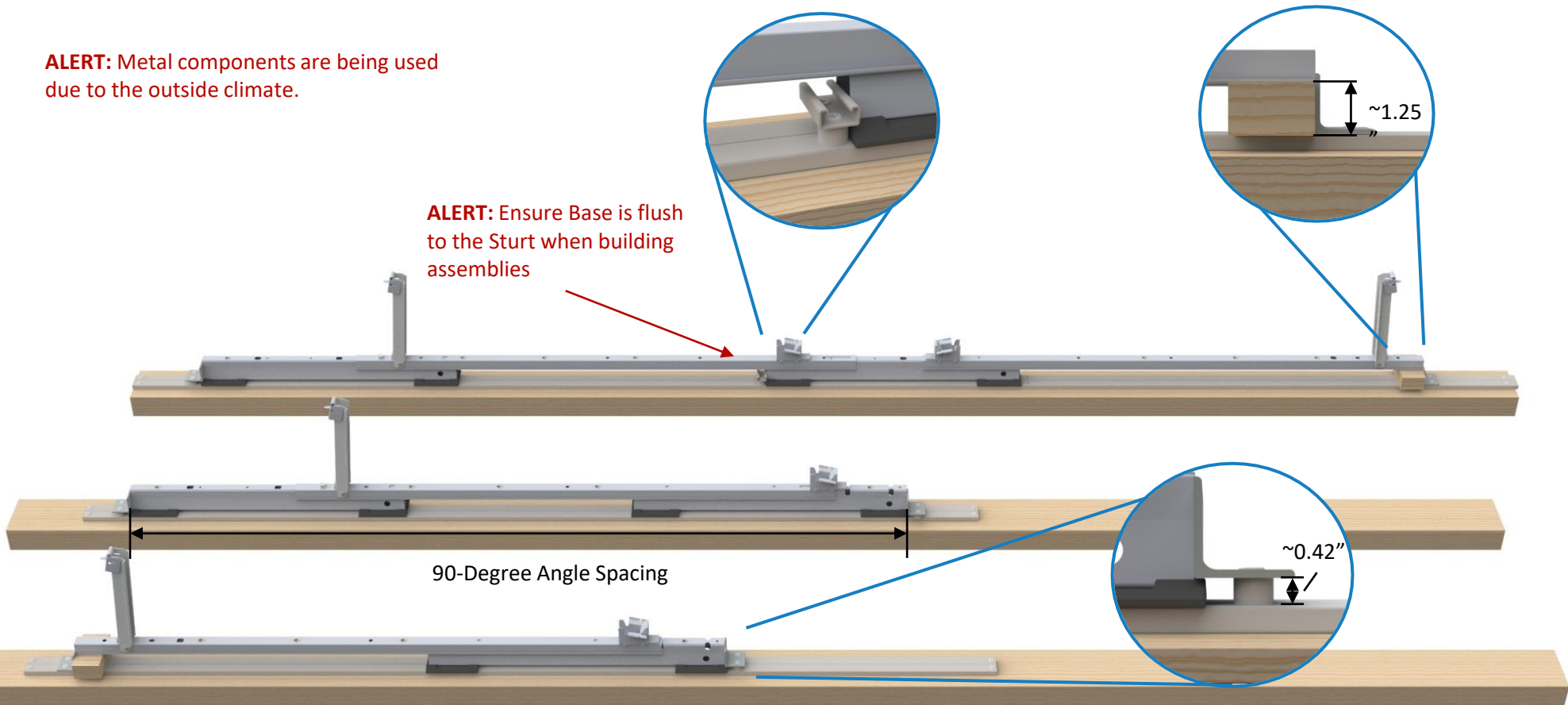

Note: The 90-Degree Angle Spacing dimension is the distance between the two 90-Degree Angles set by using one of the East, West, or Middle Valley Assemblies. This dimension changes depending on the type of Assembly used for the spacing.