

# clawFR/clawFRplus

## UL 3741

## PV Hazard Control

## Installation Addendum

### Table of Contents

Introduction and Installer's Responsibility	2
Ratings and Markings	3-5
Introduction: Understanding UL3741 and NEC 690.12	6
Installation Methods, Example Cases	7-11
UL 3741 Wire Management Guidelines	12

## Introduction

The clawFR/clawFRplus 5 Degree, 10 Degree, and Dual Tilt flat roof mounting systems are comprised of four major components that intuitively assemble into a support structure for photovoltaic (PV) modules.

This installation addendum explains how to install the 5 Degree, 10 Degree, and Dual Tilt clawFR/clawFRplus Products to meet requirements of the UL 3741 PV Hazard Control Standard. Please refer to the 5 Degree, 10 Degree and Dual Tilt Installation Manuals for complete installation instructions.



**WARNING TO REDUCE THE RISK OF INJURY, READ ALL INSTRUCTIONS**



**AVERTISSEMENT: POUR PRÉVENIR LES BLESSURES, LIRE TOUTES LES INSTRUCTIONS**

## Installer's Responsibility

### **IT IS THE INSTALLERS RESPONSIBILITY TO:**

- Ensure safe installation of all electrical aspects of the array. All electrical installation and procedures should be conducted by a licensed and bonded electrician or solar contractor. Routine maintenance of a module or panel shall not involve breaking or disturbing the bonding path of the system. All work must comply with national, state and local installation procedures, product and safety standards.
- Comply with all applicable local or national building and fire codes, including any that may supersede this manual.
- Ensure all products are appropriate for the installation, environment, and array under the site's loading conditions.
- Use only PanelClaw parts or parts recommended by PanelClaw; substituting parts may void any applicable warranty.
- Ensure provided information is accurate. Issues resulting from inaccurate information are the installer's responsibility.
- Ensure bare copper grounding wire does not contact aluminum and zinc-plated steel components, to prevent risk of galvanic corrosion.
- If loose components or loose fasteners are found during periodic inspection, retighten immediately. Any components showing signs of corrosion or damage that compromise safety shall be replaced immediately.
- Provide an appropriate method of direct-to-earth grounding according to the latest edition of the National Electrical Code, including NEC 250: Grounding and Bonding, and NEC 690: Solar Photovoltaic Systems.
- Disconnect AC power before servicing or removing modules, AC modules, microinverters, and power optimizers.
- Review module and any 3<sup>rd</sup> party manufacturer's documentation for compatibility and compliance with warranty terms and conditions.

# Ratings

**UL 2703 Listed**

**UL 3741 Listed**



**CONFORMS TO STD ANSI/CAN/UL 3741 STANDARD FOR SAFETY PHOTOVOLTAIC HAZARD CONTROL SYSTEM**

- Max PVHCS System Voltage: 1000V

**clawFR/clawFRplus List of approved PV Hazard Control Equipment or Components evaluated at 1000V Max System Voltage:**

- All modules listed in the clawFR module compatibility document with max module area of 36.8ft<sup>2</sup> or 3.4m<sup>2</sup>
- clawFR/clawFRplus Components
  - Base – 5000502XX, where XX can be 01, 02 or 03
  - Module Connector – 5000507XX, 5000523XX, 5000633XX or 5000644XX where XX can be 01 through 08
  - Cam – 5000500, 5000515, 5000630 or 5000636
  - Cam Claw – 2000673 or 2000854
  - M6 x 16mm Bolt – 2000697
  - Rail – 2000695 or 2000895
  - Wind Deflector – 2000887XX or 2000899XX, where XX can be 01 through 07
- clawFR/clawFRplus Accessories
  - MLPE Bracket Kit – 5000519 or 5000619
  - Base Pad – 2000678
  - Shim Pad – 5000228
  - Mechanical Attachment Strut – 2000830 or 2000930
  - Mechanical Hardware Kit – 5000423
  - Ground Lug Kit – 5000494
  - Lock Claw Clip – 2000819
  - Frame Enhancer – 2000832
  - Cam Seat Spacer – 2000833
  - 3rd Party Mechanical Attachments – Part Number Varies
- clawFR/clawFRplus Wire Management Products (Evaluated to UL 1565)
  - Wire Router – 500022501 and 500022502
  - Wire Clip – 5000226
  - WM Homerun Cover – 500062301 and 500062302
  - WM Homerun Clip – 5000628
- Cable Ties (UL 62275 Listed)
- Wire Clips (UL 1565 Listed)
- PV Wire (UL 4703 Listed)
- PV Connectors (UL 6703 Listed) shall be compatible and approved for the application
- RayTray v2 Solar Wire Management System (UL 870 Listed)
- Listed Conduit
  - Electrical Metallic Tubing (EMT) (UL 797 Listed)
  - Rigid Metal Conduit (RMC) (UL 6 Listed)
  - Intermediate Metal Conduit (IMC) (UL 1242 Listed)
  - Flexible Metal Conduit (UL 1 Listed)
  - Liquid Flexible Metal Conduit (UL 360 Listed)
  - Schedule 40/80 Rigid PVC Conduit (UL 651 Listed)
  - Listed Tubing, Fittings, and Grounding Components
  - Liquid Tight Flexible Non Metallic Conduit (UL 1660 Listed)

# Ratings Continued

## Approved Electrical Equipment (UL 1741 Listed)

### Canadian Solar Inverters

- CSI-75K-T480GL03-U
- CSI-80K-T480GL03-U
- CSI-90K-T480GL03-U
- CSI-100K-T480GL03-U
- CSI-75K-T480GL02-U
- CSI-100K-T480GL02-U
- CSI-66K-T480GL01-UB
- CSI-60K-T480GL01-UB
- CSI-50K-T480GL01-UB
- CSI-40K-T480GL01-UB
- CSI-36K-T480GL01-UB
- CSI-30K-T480GL01-UB
- CSI-25K-T480GL01-UB
- CSI-60KTL-GS-B
- CSI-40KTL-GS-FLB
- CSI-40KTL-GS-B
- CSI-30KTL-GS-FLB

### Chint Inverters

- CPS SCA25KTL-DO/US-208
- CPS SCA25KTL-DO-R/US-480
- CPS SCA36KTL-DOUS-480
- CPS SCA50KTL-DO/US-480
- CPS SCA60KTL-DO/US-480

### Fronius Inverters

- Fronius Symo Advanced 10.0-3 208-240/Lite
- Fronius Symo Advanced 12.0-3 208-240/Lite
- Fronius Symo Advanced 15.0-3 480/Lite
- Fronius Symo Advanced 20.0-3 480/Lite
- Fronius Symo Advanced 22.7-3 480/Lite
- Fronius Symo Advanced 24.0-3 480/Lite

### GoodWe

- GW50K-SMT-US
- GW60K-SMT-US

### SMA Inverters

- STP 33-US-41
- STP 50-US-41
- STP 62-US-41
- STP 20-US-50
- STP 25-US-50
- STP 30-US-50

### Solectria Inverters

- Solectria Renewables PVI 25TL-208
- Solectria Renewables PVI 25TL-480-R
- Solectria Renewables PVI-36TL-480-V2
- Solectria Renewables PVI 50TL-480
- Solectria Renewables PVI 60TL-480

### Solis

- S5-GC75K-US
- S5-GC80K-US
- S5-GC90K-US
- S5-GC100K-US
- Solis-25K-US (followed by –US-SW, -US-F-SW or –US-LSW)
- Solis-30K-US (followed by –US-SW, -US-F-SW or –US-LSW)
- Solis-36K-US (followed by –US-SW, -US-F-SW or –US-LSW)
- Solis-40K-US (followed by –US-SW, -US-F-SW or –US-LSW)
- Solis-50K-US (followed by –US-SW, -US-F-SW, -US-F-LSW or –US-LSW)
- Solis-60K-US (followed by -US-F-SW or –US-F-LSW)
- Solis-66K-US (followed by -US-F-SW or –US-F-LSW)
- Solis-75K-5G-US
- Solis-80K-5G-US
- Solis-90K-5G-US
- Solis-100K-5G-US
- S6-GC25K-US
- S6-GC33K-US
- S6-GC36K-US
- S6-GC40K-US
- S6-GC50K-US
- S6-GC60K-US

### Sungrow Inverters

- SG36CX-US
- SG60CX-US

### Yotta Energy Storage System (UL 9540 Listed)

- SL-1000 and DPI-208/480

Note: Requirements for PV arrays addressed in UL 3741 are intended for compliance with the National Electrical Code (NEC), NFPA 70, 2017 and later editions and their requirements for controlling electrical shock hazards inside the array boundary as addressed in NEC section 690.12(B)(2), Rapid Shutdown of PV Systems on Buildings and with the Canadian Electrical Code (CE Code) C22.1. The inverters shown above within this PVHCS additionally comply with the 30V in 30 seconds requirements outside the PV array as required in 690.12 (B)(1).

# Markings

Product markings are located on the clawFR Base and the clawFRplus Tilt Arm

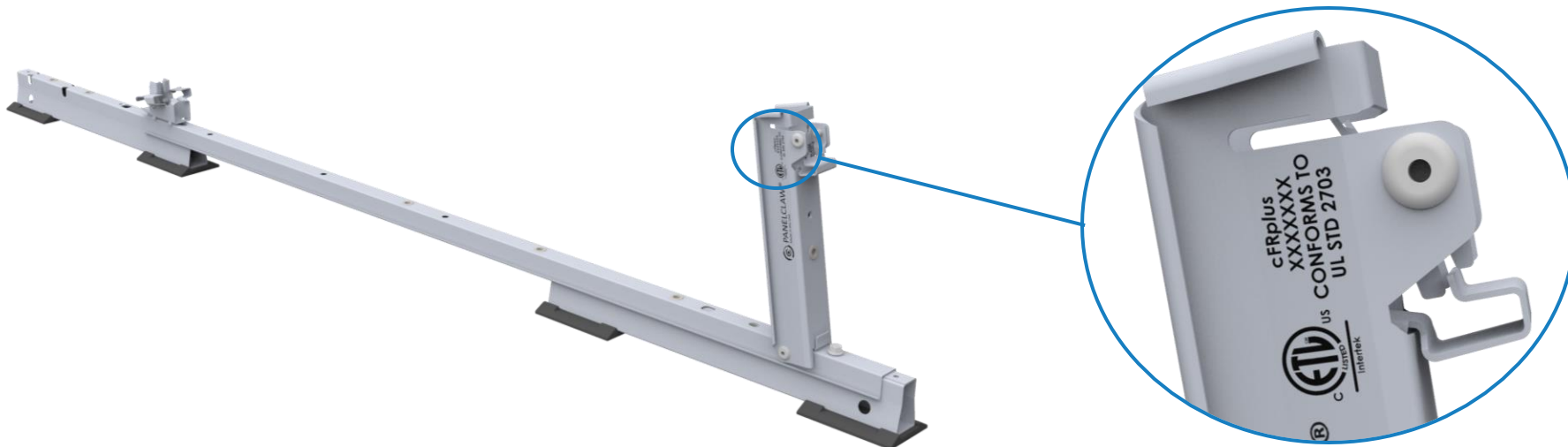

# Introduction: Understanding UL 3741 and NEC 690.12

## 2020/2023 NEC 690.12(B)(2) Controlling Conductors within the array boundary

The clawFR/clawFRplus Photovoltaic Hazard Control System (PVHCS) is a UL 3741 Listed system that complies with NEC 690.12(B)(2) (1), when installed by qualified persons per the installation procedures outlined in the clawFR System Installation Manual and this Addendum. Please refer to the following pages of this addendum for various example cases of system designs that comply with 690.12(B)(2).

## 2020/2023 NEC 690.12 Background

NEC 690.12 Rapid Shutdown of PV Systems on Buildings requires that all PV arrays installed on or in buildings shall include rapid shutdown functions to reduce shock hazard for Fire Fighters (“FF”) in accordance with 690.12(A) through (D):

### A. Controlled Conductors

1. PV system DC circuits
2. Inverter output circuits originating from inverters located within array boundary

### B. Controlled Limits

1. Outside Array Boundary:  $\leq 30V$  within 30 seconds
2. Inside Array Boundary – The PV System shall comply with one of the following:
  1. Listed PV Hazard Control System (UL 3741)
  2.  $\leq 80V$  within 30 seconds after rapid shutdown initiation
  3. PV array without exposed wiring methods or conductive parts (NEC 2020 only)

### C. Initiation devices

- Initiation device(s) shall initiate the rapid shutdown function of the PV system

### D. NEC 2020 - Equipment

- Equipment that performs rapid shutdown functions, other than initiation devices such as listed disconnect switches, circuit breakers, or control switches, shall be listed for providing rapid shutdown protection.

### E. NEC 2023 - Buildings with Rapid Shutdown

- Buildings with PV systems shall have a permanent label located at each service equipment location to which the PV systems are connected or at an approved readily visible location and shall indicate the location of rapid shutdown initiation devices.

- NEC 690.2 (2020) or Article 100 (2023) defines the array as a mechanically and electrically integrated grouping of modules with support structure, including any attached system components such as inverter (s) or dc-to-dc converter(s) and attached associated wiring.
- NEC 690.12(B) defines the array boundary as 1ft from array in all directions. This indicates that the array boundary can extend 1ft from the edge of the clawFR/clawFRplus racking, inverter, or module.
- The inverter is considered within the array boundary if mechanically attached and within 1 foot of the mounting system or module.

# Installation Methods Per UL 3741 and NEC 690.12

The following case studies are provided by PanelClaw to illustrate examples of installation configurations that comply with NEC 690.12(B), compliance is not limited to these examples.

**Case 1: UL 3741 Listed System**

**Case 2: UL 3741 Listed System with Contiguous Sub-Array**

**Case 3: UL 3741 Listed System with Non-Contiguous Sub-Array**

**Case 4: UL 3741 Listed System with MLPE Sub-Array**

The simplest installation method to comply with NEC690.12(B) is to utilize the clawFR UL 3741 system with a contiguous array with one or more collocated inverters, as all inverter DC input circuits are within the 1ft array boundary (Case 1). Installations where sub-arrays are required and cannot be included within the 1 ft array boundary can comply by using a single or combining one or more of the three options below (Cases 2-4).

Case studies and NEC Guidance have not been verified by Intertek.

# UL 3741 Listed System, Case 1:

Array(s) comply with  
 NEC 690.12(B)(2)(1)

## PV Circuit Voltages:

- **Outside Array Boundary:**  
 $\leq 30V$  within 30 Seconds
- **Inside Array Boundary:**  
 $\leq 1000V$

## Case 1: Array(s) complies with 690.12(B) by utilizing a listed UL 3741 PV Hazard Control System

- All inverter input circuits (DC) are contained within the PV array boundary and do not require additional measures to reduce string voltages per 690.12(B)(2)(1) after initiation (Inverter DC disconnect, AC breaker or AC disconnect).
- Inverter output circuits (AC) are outside of the array boundary and meet the 690.12(B)(1) requirement after initiation (AC breaker or AC disconnect).

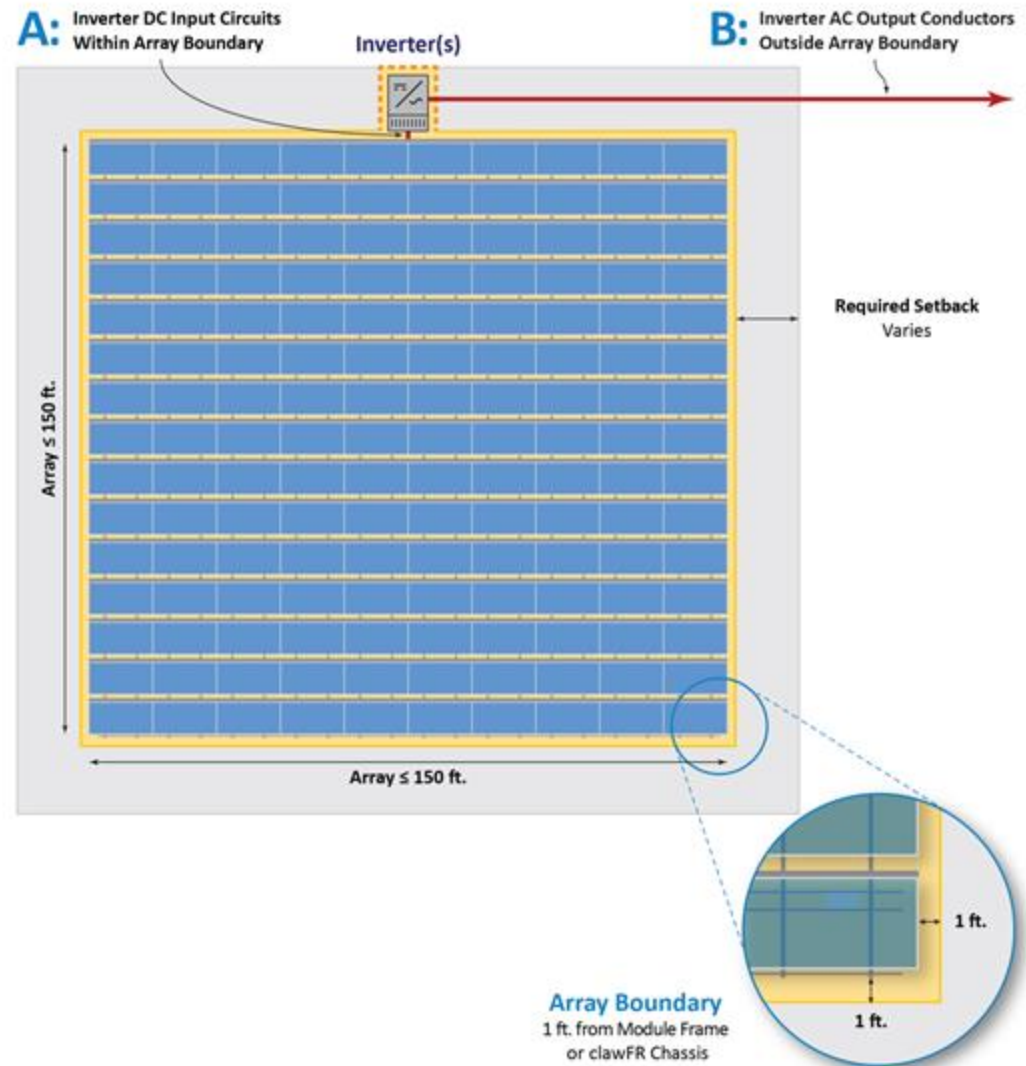



# UL 3741 Listed System, Case 2:

Sub-Array(s) are within the same array Boundary and Array(s) comply with NEC 690.12(B)(2)(1)

## PV Circuit Voltages:

- **Outside Array Boundary:**  
 $\leq 30V$  within 30 Seconds
- **Inside Array Boundary:**  
 $\leq 1000V$

## Case 2: Maintaining NEC Compliance with sub-array(s) within array boundary

Maximum 2 ft. spacing between all array components resulting in a single array boundary.

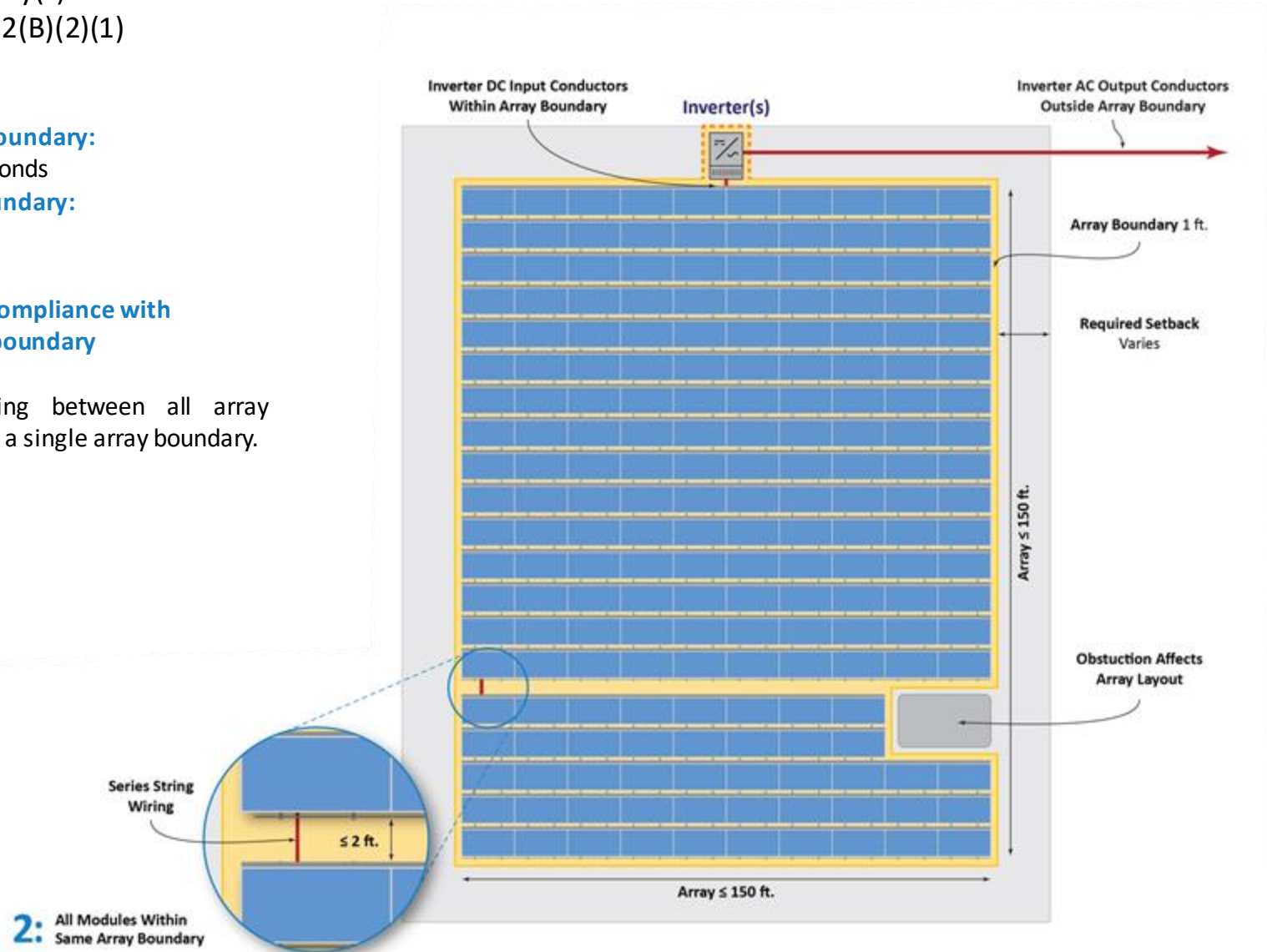

# UL 3741 Listed System, Case 3:

Multiple Sub-Arrays with conductors outside of Array Boundary are controlled via String Isolation Device(s)

## PV Circuit Voltages:

- **Outside Array Boundary:**  
 $\leq 30V$  within 30 Seconds
- **Inside Array Boundary:**  
 $\leq 1000V$

## Case 3: Maintaining NEC Compliance with conductors installed between multiple sub-arrays

Complete string must be connected to a single isolation device.

If used for a partial string, isolation devices required on both sides of the pathway since voltage will be present on both sides.

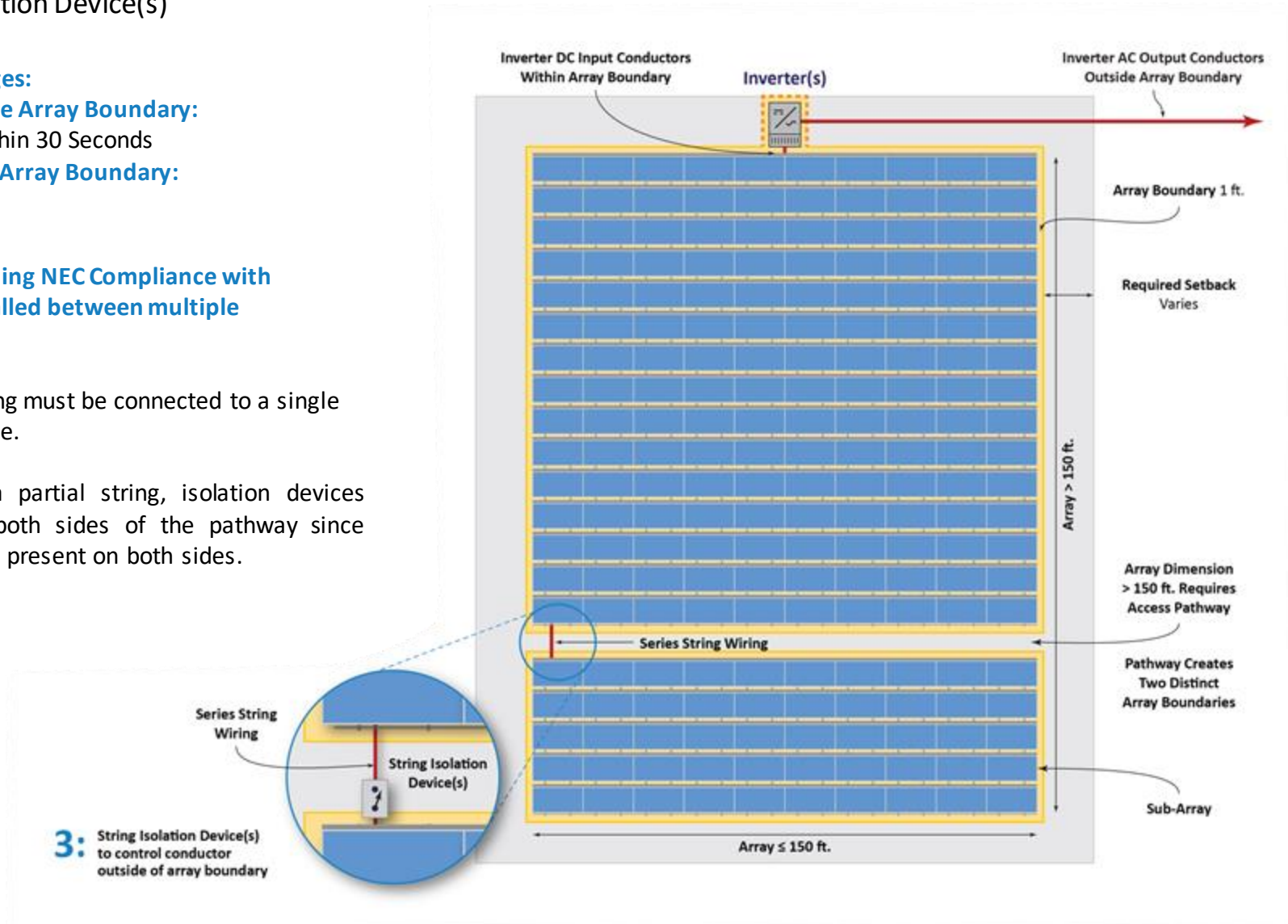

# UL 3741 Listed System, Case 4 (using MLPE):

Sub-array(s) using MLPEs to control circuits for 690.12(B)(1) and (B)(2) compliance

## PV Circuit Voltages:

- **Outside Array Boundary:**  
 $\leq 30V$  within 30 Seconds
- **Inside Array Boundary:**  
 $\leq 1000V$
- **Sub-Array Boundary:**  
 $\leq 80V$  Inside within 30 Seconds

## Case 4: Maintaining NEC Compliance with sub-array(s) outside of array Boundary

Utilize Module-Level Power Electronics on lower sub-array.

All modules on the same inverter input must be connected to an MLPE. Upper array utilizes UL 3741 listing without MLPEs for compliance.

**4:** Listed Module Level Power Electronics

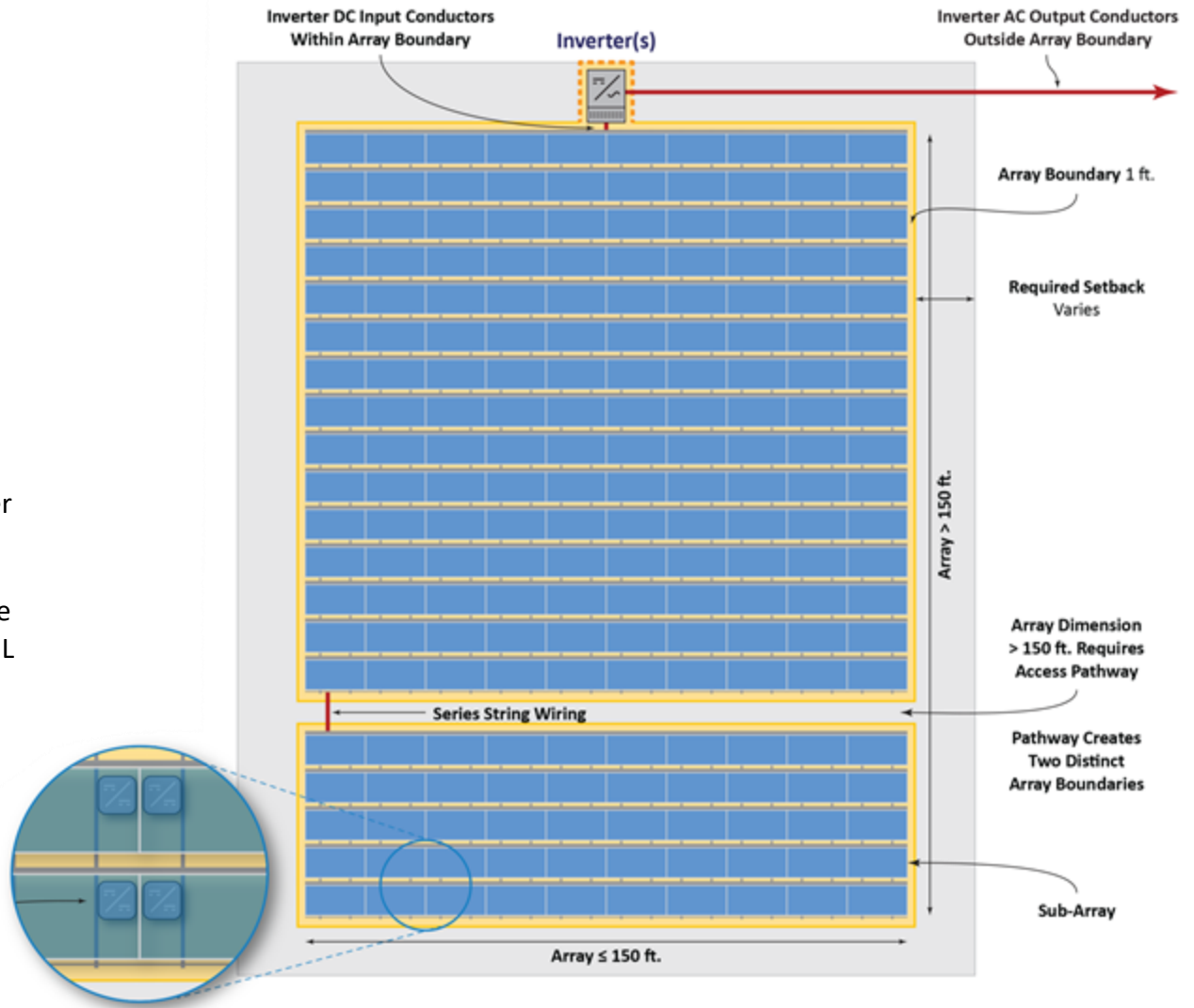

**ALERT:** When using MLPE devices, review installation instructions for both the MLPE device and Inverter to verify that both devices are compatible and comply with UL 1741 Rapid Shutdown requirements.

# UL 3741 Wire Management Guidelines

All wires shall be routed such that they are not exposed to potential FF interactions. The clawFR Wire management components noted in the list of approved PVHCS equipment on [page 3](#) were evaluated and approved.

- Routing all wires under modules and along module rows shall be accomplished with the clawFR Wire Clip or other UL Listed cable ties or UL Listed wire management devices.
- Routing all wires across rows shall be accomplished with the clawFR Homerun Cover, clawFR Wire Router, or approved listed raceway for wires crossing over a pathway.
- Manage larger bundles of wires using clawFR Homerun Clip and Cover, or other UL Listed Raceway. When entering and exiting the raceway, installers shall ensure wires are routed away from exposure to Fire Fighter interactions.

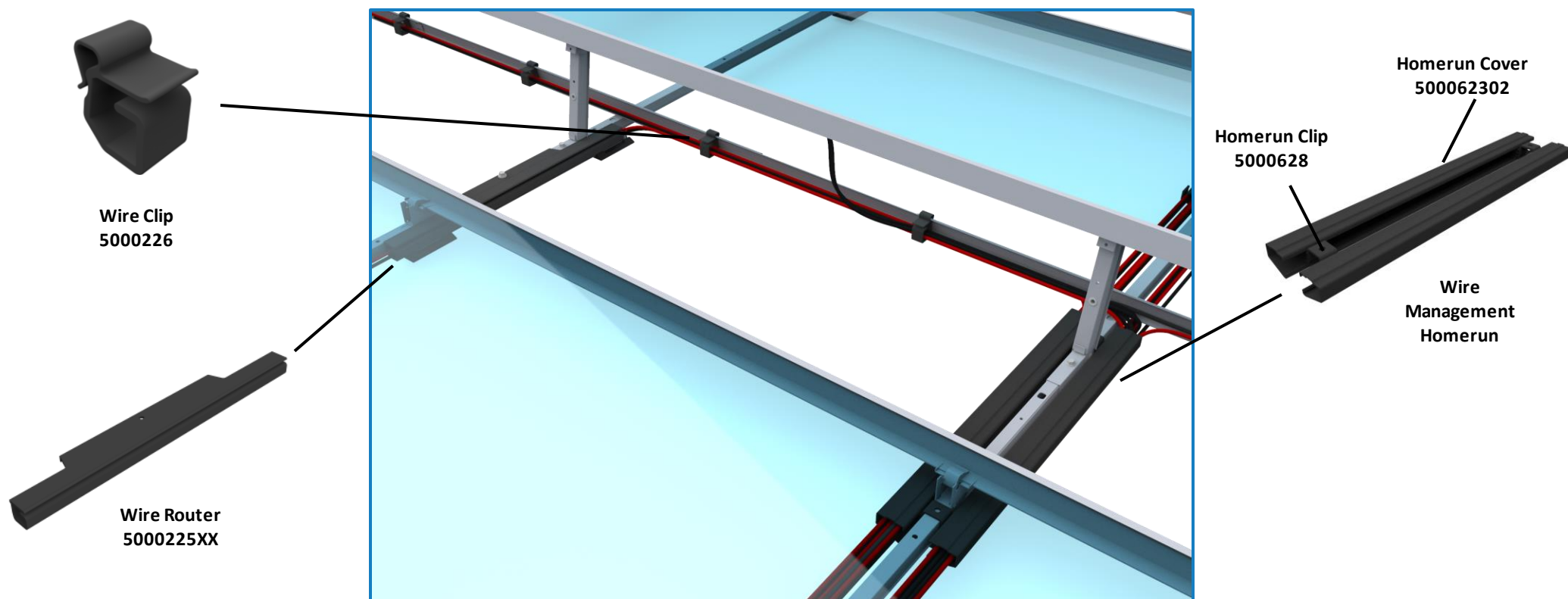

**Note:** Installers shall refer to the clawFR Wire Management manual for complete installation instructions of Wire Management Accessories