



## clawFRplus 5/10 Degree Assembly Jig

### Why Build a Jig?

The clawFRplus installation manuals outline a process for constructing assemblies that consists of repeated use of the “Cam Spacer” (see page 7 of the clawFRplus 10D and 5D installation manuals). Building an Assembly Jig will expedite construction of the assemblies and increase quality by eliminating the use of the cam spacer after template assemblies are made. All assemblies following the template assemblies can be made using the jig without use of the cam spacer.

# Assembly Jig Components



4' x 8' x 1/4" Plywood



6' Extra Low-Profile  
Strut Channel

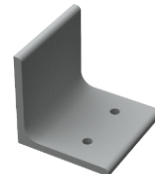

1/8" Thick 90 Degree  
Angle



No. 6, 1-1/2" Steel  
Wood Screw



1-1/4" Thick Wood  
Block



General Stainless-Steel  
Washer for No. 6  
Screw Size

**Note:** These are common parts that can be bought from a preferred vendor.

**Note:** All clawFRplus components necessary for the assemblies are supplied. For a list of these components see page 4 of the clawFRplus instruction manual.

**Alert:** The components listed for the jig are not supplied.

## Tools

- Power Drill
- No. 2 Phillips Driver
- 9/64" Drill Bit (Metal Rated)

**Alert:** See page 5 of the installation manual for the necessary tools and torque limits required to assemble the clawFRplus assemblies.

# Build Assembly Jig

- 1 Take a sheet of plywood or equivalent. Place two 6' sections of Uni-Strut stock flat side face up, side by side on the plywood sheet. Drill two holes at each end of the Uni-Strut pair, fastening them to the plywood sheet using drywall screw or other means.

**ALERT:** Please note this is to be done on both ends of the Uni-Strut pair.

- 2 For each assembly, cut two pieces of 90-degree Angle stock to width of the Uni-Strut pairs, drilling two holes equal distance apart within center of Uni-Strut. Using an appropriate number of washers screw down through the 90-degree Angle into the plywood with drywall screw or other means.

- 3 Build a North, Middle, South, and North/South assembly (if applicable) using the Cam dimensions provided within the Racking Construction Set. These assemblies will be used to set jig spacing.

**ALERT:** See "Build Assemblies" Section of the clawFRplus Installation Manual on how to properly assemble the North, Middle, South, and North/South assemblies.

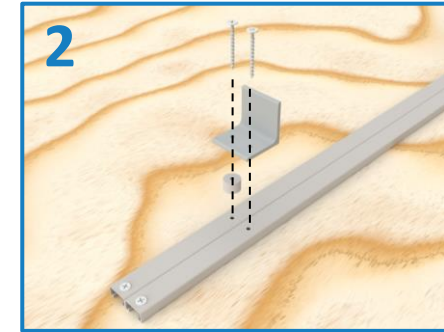
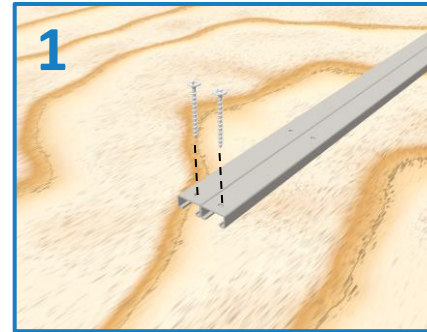

3



South Assembly



North Assembly



Middle Assembly



North-South Assembly



**ALERT:** Align 90-degree Angle stock with Base, not Base Pad.

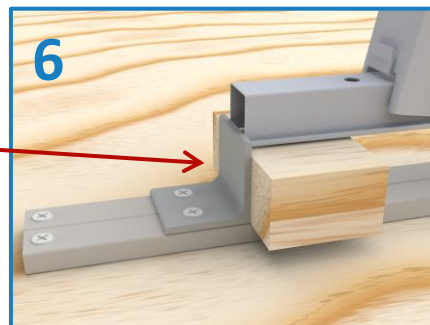

**ALERT:** Align 90-degree Angle stock with the end of the Module Connector.

- 4 Place assembly onto the Uni-Strut Pair. Align the assembly so that one side of the end of the base is flush with the attached 90-Degree Angle. This Assembly will set the reference distance.

**Alert:** If the 90-Degree Angle is colliding with the Base Pad add more washers until the 90-Degree Angle clears the Base Pad.

- 5 On the opposite end of the assembly repeat Step 2 to mount the second 90-Degree Angle to the plywood ensuring that the 90-degree angle is tightly flush with the base.

- 6 For Middle and South Assemblies, cut a block of wood at 1.25" thick to the width of the Uni-Strut pairs. Place underneath Module Connector to keep assembly level opposite of the Base.

**Tip:** Wood block can be replaced with equivalent sized object.

# clawFRplus Assembly Jig (10D/5D)

**Note:** The size of the Uni-Strut Channels and the 90-Degree Angles, as well as the location of the drilled holes are not critical dimensions. What is important is the North-South spacing of the 90-Degree Angles. As long as the North, South, Middle, and North-South Template Assemblies are correctly assembled using the dimensions provided in the Construction Racking Set and the 90-degree angles are set flush to the assemblies than the jig can be used to construct all further assemblies.

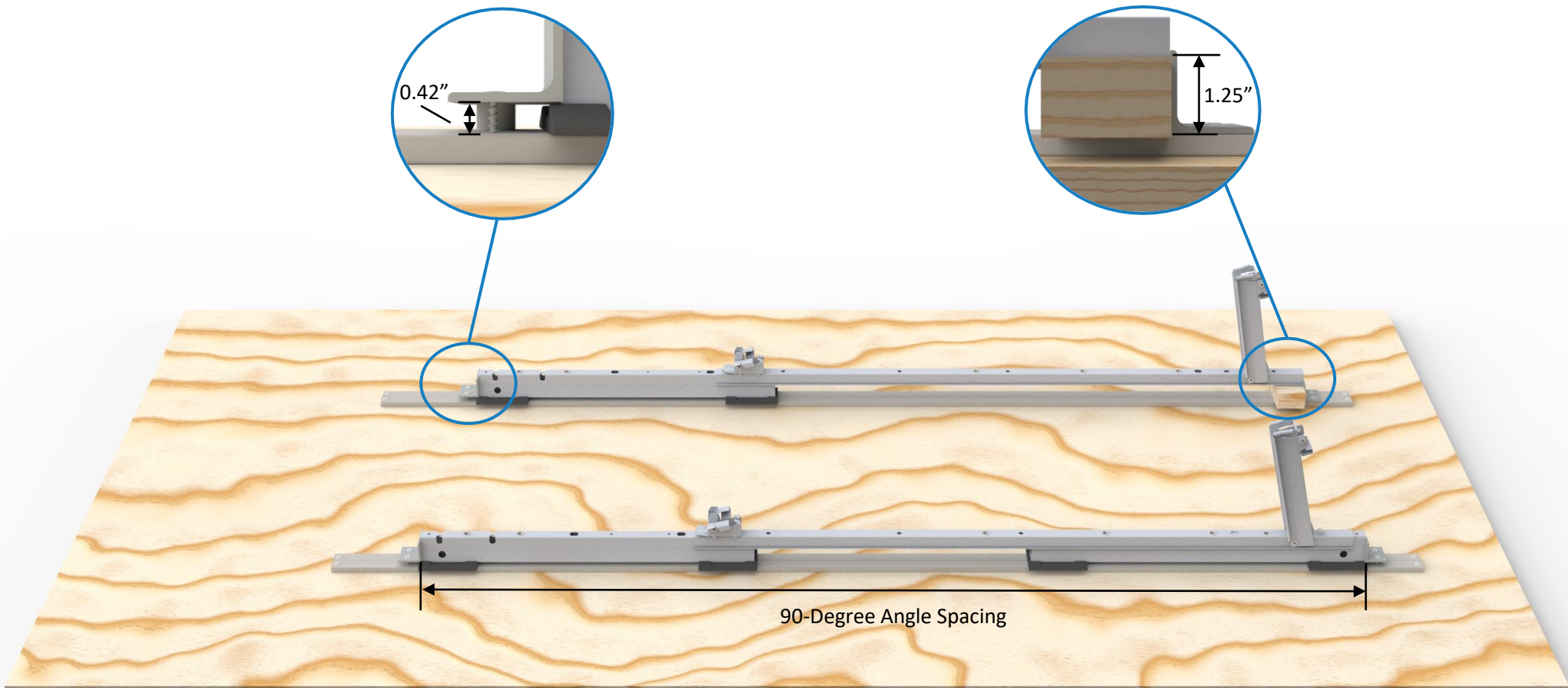

**Note:** The 90-Degree Angle dimension is the distance between the two 90-Degree Angles set by using one of the North, South, Middle, or North-South Assemblies. This dimension changes depending on the type of Assembly used for the spacing.